

1. Part No. Expression

SCTQ50046R3KA11D

(a) (b) (c) (d) (e)

- (a) Series Code
- (b) Dimension Code
- (c) Inductance Code
- (d) Tolerance Code
- (e) Internal Code

2. Configuration & Dimensions (Unit: mm)

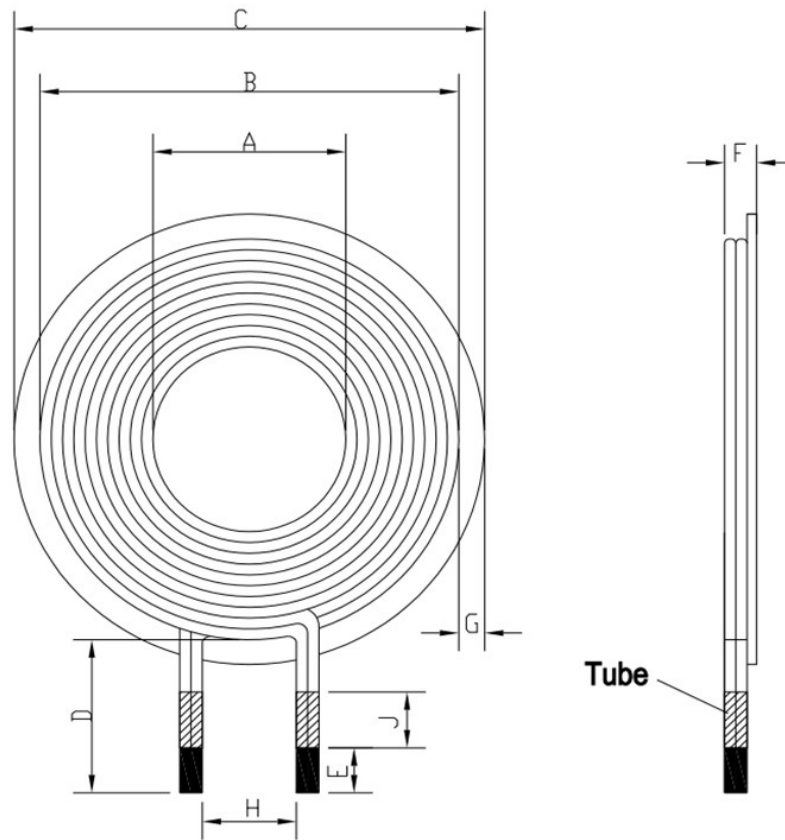

A	B	C	D	E	F	G	H	J
20.5±0.5	44.0±1.5	50.0±0.5	17.0±2.0	5.0±2.0	4.0 Max	2.0 Min	10.0 Ref	8.0 Ref

NOTE: Specifications subject to change without notice. Please check our website for latest information.

3. Schematic



4. Material List

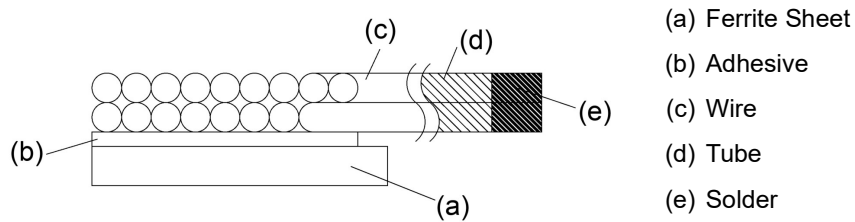

5. General Specifications

- (a) Reliability test for this part meets AEC-Q200 standard.
- (b) Compatible with Qi standard A11 design.
- (c) Operating Temp.: -40°C to +125°C (including self-temperature rise)
- (d) Storage Temp.: -40°C to +125°C (on board)
- (e) Heat Rated Current (I_{rms}) will cause the coil temperature rise approximately ΔT of 40°C Max.
- (f) Power Rating: 5W

6. Electrical Characteristics

Inductance (μH) $\pm 10\%$	Test Frequency	DCR ($m\Omega$) Max	I _{rms} (mA) Max
6.3	1V/100kHz	25	10000

NOTE: Specifications subject to change without notice. Please check our website for latest information.



7. Soldering Specification

Mildly activated rosin fluxes are preferred. The minimum amount of solder can lead to damage from the stresses caused by the difference in coefficients of expansion between solder, chip and substrate. Our terminations are suitable for wave soldering.

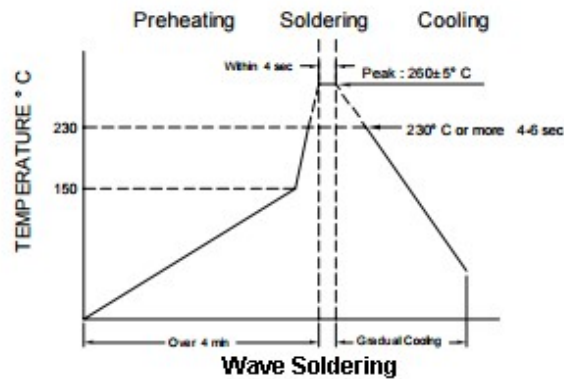

Application Notice

1. Storage Conditions

To maintain the solderability of terminal electrodes:

- (a) Recommended products should be used within 12 months from the time of delivery.
- (b) The packaging material should be kept where no chlorine or sulfur exists in the air.

2. Transportation

- (a) Products should be handled with care to avoid damage or contamination from perspiration and skin oils.
- (b) Vacuum pick up is strongly recommended for individual components.
- (c) Bulk handling should ensure that abrasion and mechanical shock are minimized.

NOTE: Specifications subject to change without notice. Please check our website for latest information.