

1. Part No. Expression:

Z 3 K 3 0 0 - R N - □ □  
 (a)(b)(c) (d) (e)(f) (g)

(a) Series code

(b) Dimension code

(c) Material code

(d) Impedance code : 300 = 30.0Ω

(e) R : Reel

(f) Current : N = 3000mA

(g) 10: Standard

11 ~ 99 : Internal control number

2. Configuration & Dimensions:

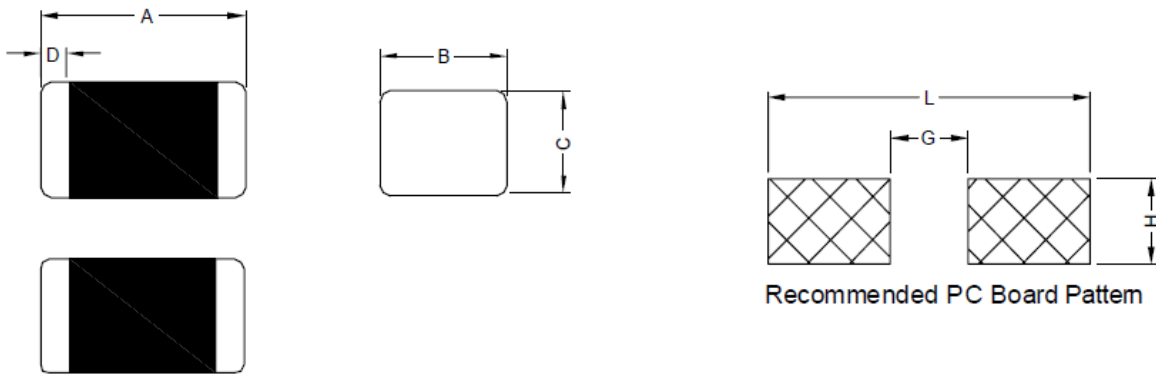

Unit:m/m

A	B	C	D	G	H	L
2.00± 0.20	1.25± 0.20	0.85± 0.20	0.50± 0.30	1.00 Ref.	1.00 Ref.	3.00 Ref.

3. Schematic

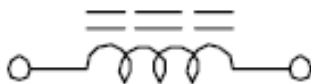

4. Material List:

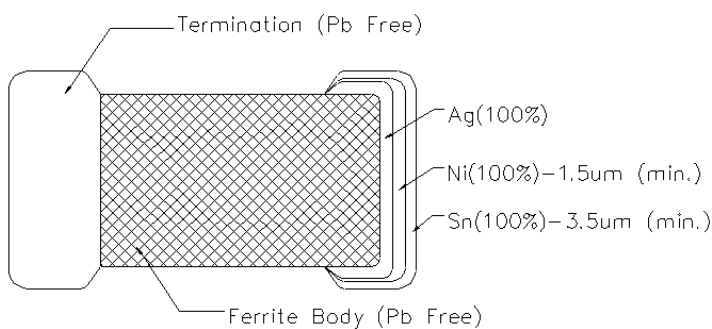

NOTE: Specifications subject to change without notice. Please check our website for latest information.

## 5. General Specification:

- (a) Operating Temp.: -55°C to +125°C (Including self-temperature rise).
- (b) Storage Condition (Component in its packaging)
  - i) Temperature: Less than 40°C.
  - ii) Humidity: 60% RH.

## 6. Electrical Characteristics:

Part Number	Impedance ( Ω )	Test Frequency ( MHz )	DC Resistance ( Ω ) Max.	Rated Current ( mA ) Max.
Z3K300-RN-10	30 ± 25%	100	0.04	3000
Z3K800-RN-10	80 ± 25%	100	0.04	3000
Z3K121-RL-10	120 ± 25%	100	0.10	2000
Z3K151-RL-10	150 ± 25%	100	0.10	2000
Z3K221-RL-10	220 ± 25%	100	0.10	2000
Z3K301-RJ-10	300 ± 25%	100	0.20	1000
Z3K471-RJ-10	470 ± 25%	100	0.20	1000
Z3K601-RJ-10	600 ± 25%	100	0.20	1000

NOTE: Specifications subject to change without notice. Please check our website for latest information.



7. Characteristics Curve:

Z3K300-RN-10

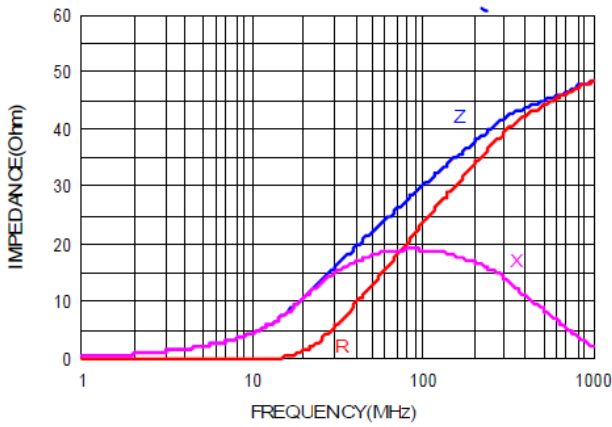

Z3K800-RN-10

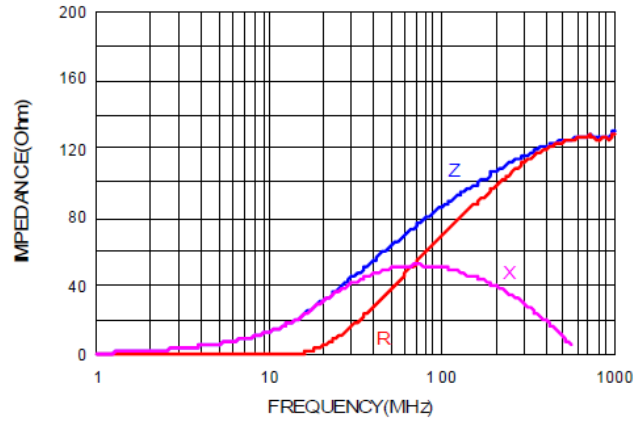

Z3K121-RL-10

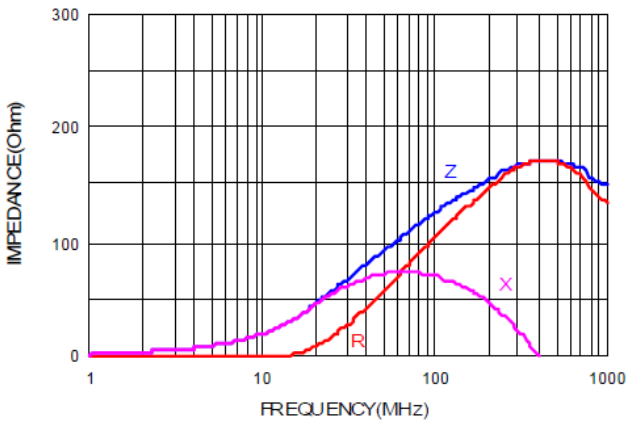

Z3K151-RL-10

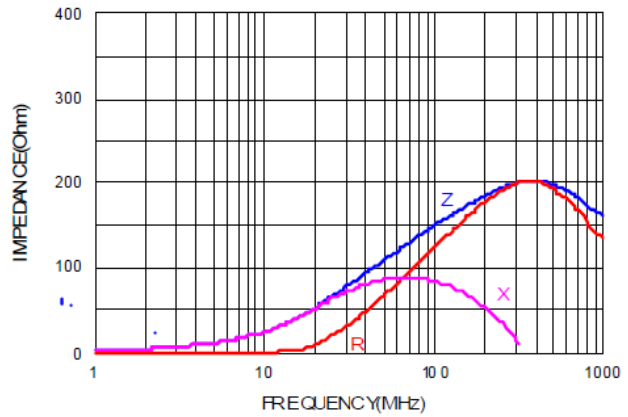

Z3K221-RL-10

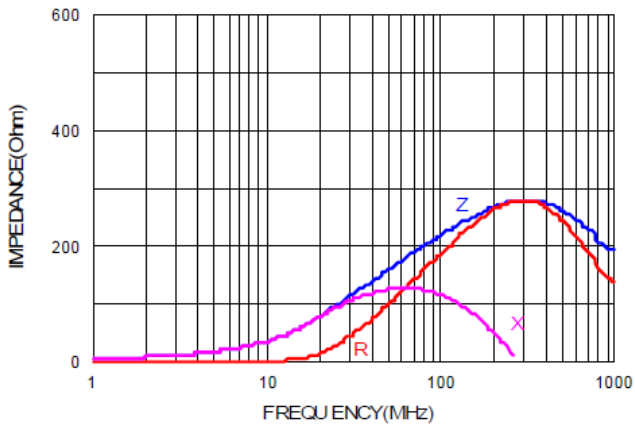

Z3K301-RJ-10

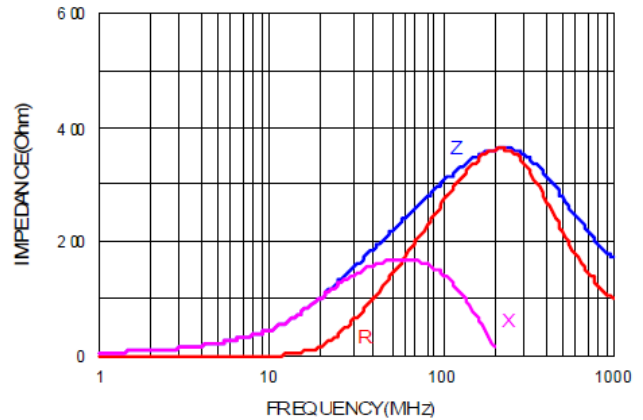

NOTE: Specifications subject to change without notice. Please check our website for latest information.



Z3K471-RJ-10

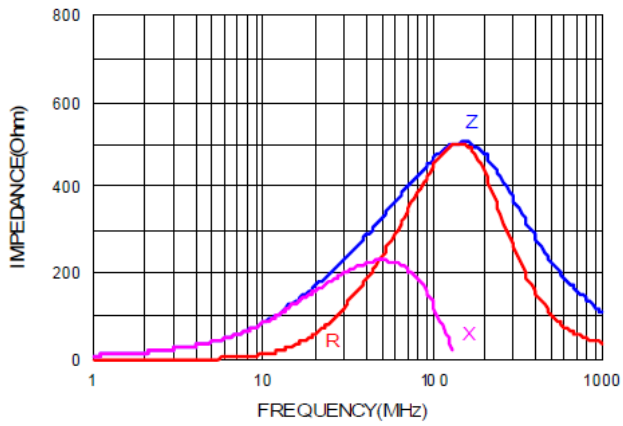

Z3K601-RJ-10

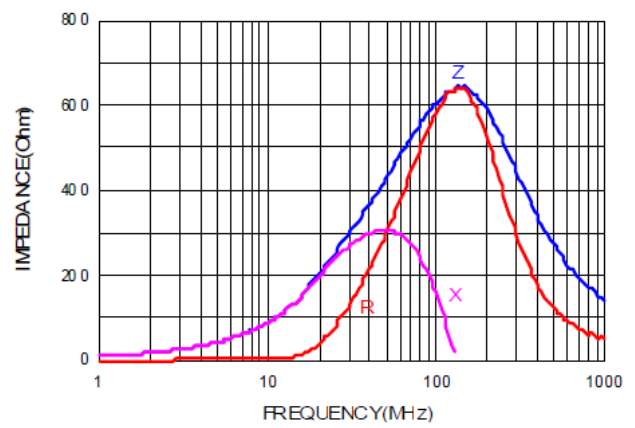

NOTE: Specifications subject to change without notice. Please check our website for latest information.



### 8. Soldering:

Mildly activated rosin fluxes are preferred. Our terminations are suitable for all re-flow soldering systems. If hand soldering cannot be avoided, the preferred technique is the utilization of hot air soldering tools.

Note:

- If wave soldering is used, there will be some risk.
- Re-flow soldering temperatures below 240 degrees, there will be non-wetting risk

#### 8-1 Solder Re-flow:

Recommended temperature profiles for re-flow soldering in Figure 1.

#### 8-2 Soldering Iron (Figure 2):

Products attachment with soldering iron is discouraged due to the inherent process control limitations. In the event that a soldering iron must be employed the following precautions are recommended.

Note :

- a) Preheat circuit and products to 150°C.
- b) 350°C tip temperature (Max.)
- c) Never contact the ceramic with the iron tip
- d) 1.0mm tip diameter (Max.)
- e) Use a 20 watt soldering iron with tip diameter of 1.0mm
- f) Limit soldering time to 4~5 sec.

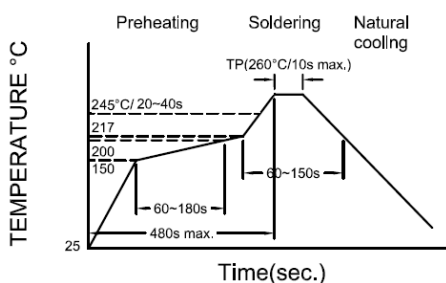

Figure 1. : Re-flow Soldering time 3 times Max.

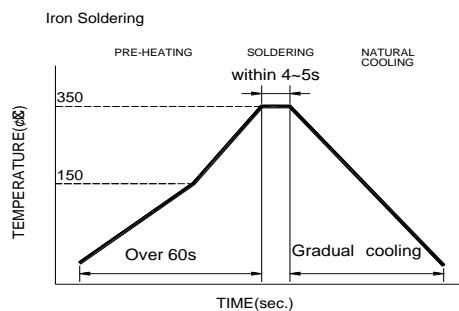
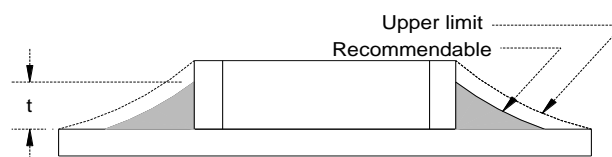

Figure 2. : Iron Soldering time 1 times Max.

#### 8-3 Soldering Volume:

Accordingly increasing the solder volume, the mechanical stress to product is also increased. Exceeding solder volume may cause the failure of mechanical or electrical performance. Solder shall be used not to be exceeding as shown in the Figure below. Minimum fillet height = soldering thickness + 25% product height.



NOTE: Specifications subject to change without notice. Please check our website for latest information.



9. Packaging Information:

9-1 Reel Dimension

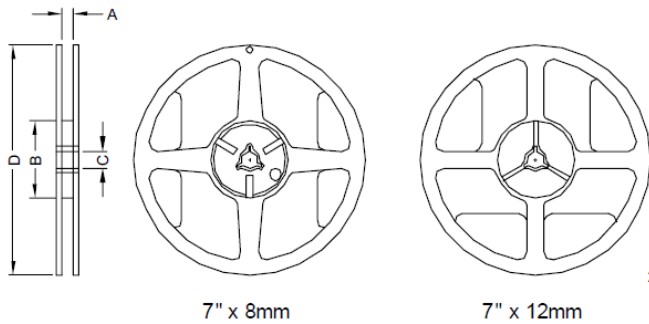

Type	A(mm)	B(mm)	C(mm)	D(mm)
7" x 8mm	9.0±0.5	60.0±2.0	13.5±0.5	178.0±2.0
7" x 12mm	13.5±0.5	60.0±2.0	13.5±0.5	178.0±2.0

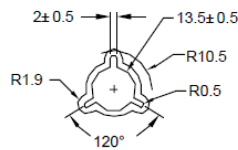

9-2.1 Tape Dimension / 8mm

Material of taping is paper

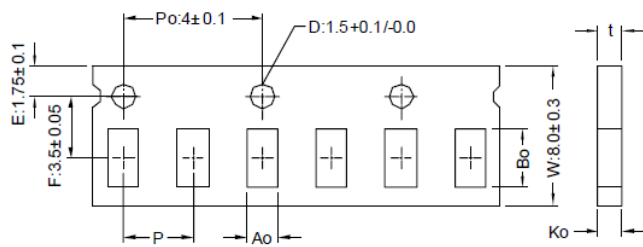

Size	Bo(mm)	Ao(mm)	Ko(mm)	P(mm)	t(mm)
0	0.68±0.05	0.38±0.05	0.50max	2.0±0.05	0.50max

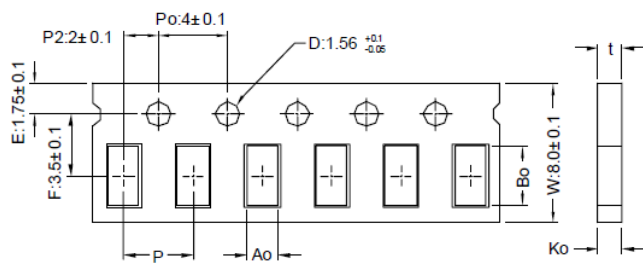

Size	Bo(mm)	Ao(mm)	Ko(mm)	P(mm)	t(mm)
1	1.12±0.03	0.62±0.03	0.60±0.03	2.0±0.10	0.60±0.03
2	1.85±0.05	1.05±0.05	0.95±0.05	4.0±0.10	0.95±0.05
3(09)	2.30±0.05	1.50±0.05	0.95±0.05	4.0±0.10	0.95±0.05

Material of taping is plastic

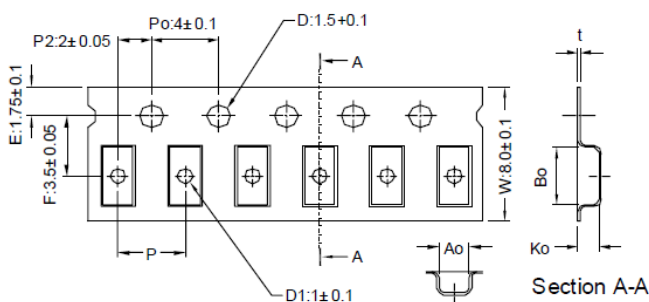

Size	Bo(mm)	Ao(mm)	Ko(mm)	P(mm)	t(mm)	D1(mm)
2(08)	1.95±0.10	1.05±0.10	1.05±0.10	4.0±0.10	0.23±0.05	none
3(09)	2.25±0.10	1.42±0.10	1.04±0.10	4.0±0.10	0.22±0.05	1.0±0.10
3(12)	2.35±0.10	1.50±0.10	1.45±0.10	4.0±0.10	0.22±0.05	1.0±0.10
4(11)	3.50±0.10	1.88±0.10	1.27±0.10	4.0±0.10	0.22±0.05	1.0±0.10
5	3.42±0.10	2.77±0.10	1.55±0.10	4.0±0.10	0.22±0.05	1.0±0.10
4(09)	3.40±0.10	1.77±0.10	1.04±0.10	4.0±0.10	0.22±0.05	1.0±0.10

NOTE: Specifications subject to change without notice. Please check our website for latest information.



9-2.2 Tape Dimension / 12mm

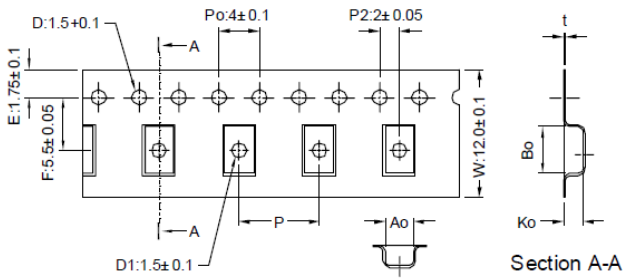

Series	Size	Bo(mm)	Ao(mm)	Ko(mm)	P(mm)	t(mm)	D1(mm)
Z / L	6	4.95±0.1	1.93±0.1	1.93±0.1	4.0±0.1	0.24±0.05	1.5±0.1
	7	4.95±0.1	3.66±0.1	1.85±0.1	8.0±0.1	0.24±0.05	1.5±0.1

9-3. Packaging Quantity

Chip Size	7	6	5	4(11)	4(09)	3(12)	3(09)	2	1	0
Chip / Reel	1000	2000	2500	3000	3000	2000	4000	4000	10000	15000
Inner Box	4000	8000	12500	15000	15000	10000	20000	20000	50000	75000
Middle Box	20000	40000	62500	75000	75000	50000	100000	100000	250000	375000
Carton	40000	80000	125000	150000	150000	100000	200000	200000	500000	750000

9-4 Tearing Off Force

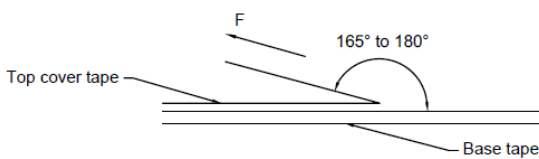

The force for tearing off cover tape is 15 to 60 grams in the arrow direction under the following conditions.

Room Temp. (°C)	Room Humidity (%)	Room atm (hPa)	Tearing Speed mm/min
5~35	45~85	860~1060	300

**Application Notice:**

1. Storage Conditions:

To maintain the solderability of terminal electrodes:

- a) Recommended products should be used within 12 months from the time of delivery.
- b) The packaging material should be kept where no chlorine or sulfur exists in the air.

2. Transportation:

- a) Products should be handled with care to avoid damage or contamination from perspiration and skin oils.
- b) Vacuum pick up is strongly recommended for individual components.
- c) Bulk handling should ensure that abrasion and mechanical shock are minimized.

NOTE: Specifications subject to change without notice. Please check our website for latest information.

