

1. Part No. Expression:

W M R S 5 0 5 0 0 5 1 2 V 1 R 7 A

(a) (b) (c)

- a) Series Code
- b) Dimension Code
- c) Power Rating Code

2. Configuration & Dimensions: (Unit:- mm)

- PCB 50.04 mm x 50.04 mm x 5 mm

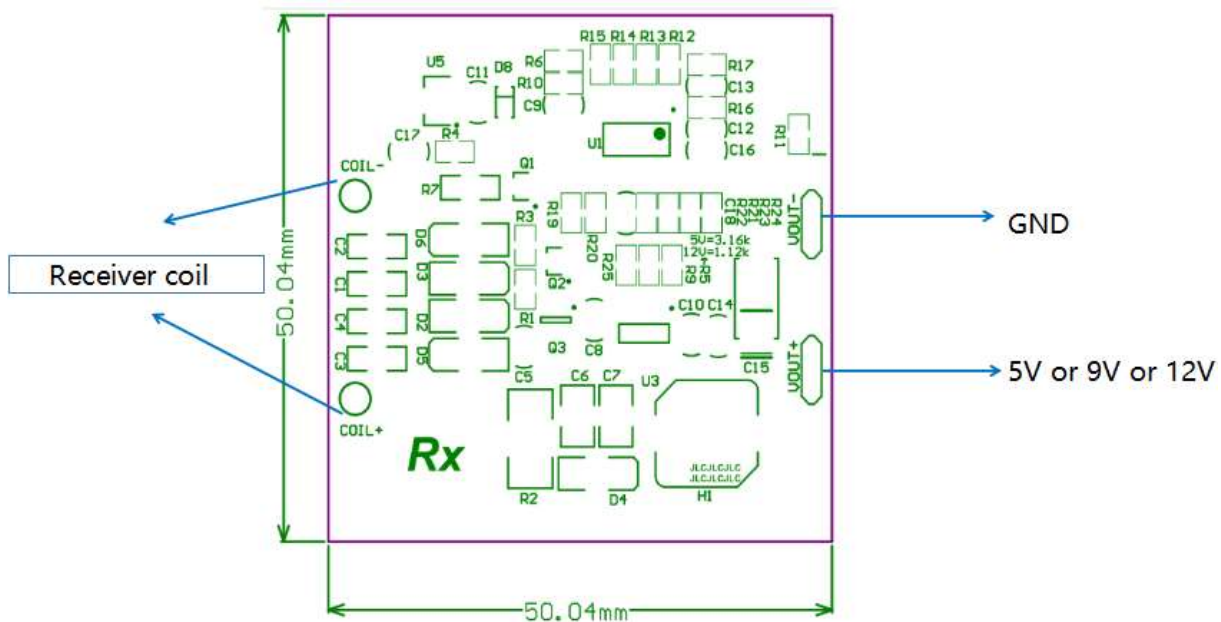

- Coil 50 mm x 50 mm x 3.5 mm

3. General Specifications:

- a) Operating Temp. : 0°C to +40°C
- b) Storage Temp. : -30°C to +70°C
- c) Once Rx receiver is identified, Tx Module will output power by automatic adjustment.
- d) Power overload and metal sensing protection.
- e) The surface distance between Tx Coil & Rx Coil is 5-30mm.
- f) Must use with WMTS57621015V.
- g) This module is not Qi compatible.

NOTE: Specifications subject to change without notice. Please check our website for latest information.

4. Electrical Specifications:

- Receiver unit

Description	Remarks	Min.	Typ.	Max.	Unit
Output Voltage	Load current at 1.7A	11.4	12.5	12.6	V
	Load current at 2.5A	4.75	5	5.25	
Output Current	Constant Voltage = 12V			1.7	A
	Constant Voltage = 5V			2.5	
Output voltage ripple				200	mV
System Efficiency	Load with SWS 20W Transmitter module			75	%
System Frequency		50		500	KHz

5. LED Indications:

- LED off – no power
- LED On Flashing – operating mode

NOTE: Specifications subject to change without notice. Please check our website for latest information.

