

1. Part No. Expression:

WAEL445R0-RK-10

(a) (b) (c) (d) (e)(f) (g)

- (a) Series Code
- (b) Dimension Code
- (c) Internal Controlled Number
- (d) Inductance Code
- (e) Packaging Code
- (f) Current Code
- (g) Standard Code

2. Configuration & Dimensions:

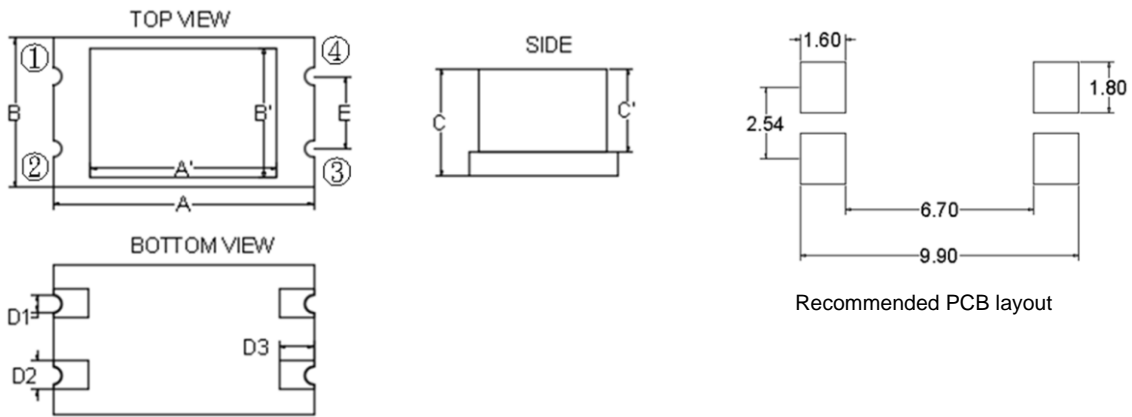

Unit: mm

Series	A	A'	B	B'	C	C'	D1	D2	D3	E
WAEL44	9.10±0.2	4.50±0.2	5.17±0.2	3.20±0.2	3.80±0.2	2.80±0.2	0.60±0.1	1.00±0.1	1.20±0.1	2.50±0.2
WAEL46	9.10±0.2	6.50±0.3	5.17±0.2	4.50±0.2	3.80±0.2	2.70±0.2	0.60±0.1	1.00±0.1	1.20±0.1	2.50±0.2

3. Schematic:

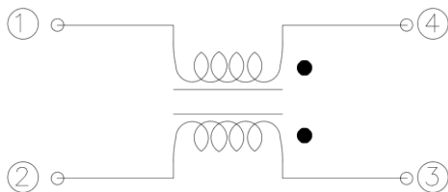

NOTE: Specifications subject to change without notice. Please check our website for latest information.



4. Measuring Circuits:

Common mode

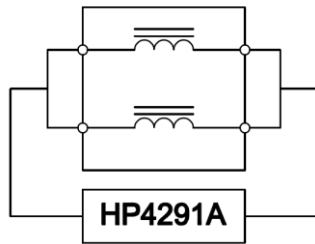

Differential mode

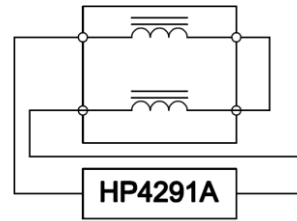

5. Material List:

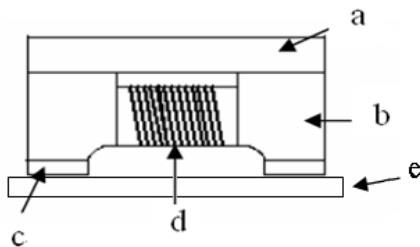

- (a) Upper Plate
- (b) Core
- (c) Termination
- (d) Wire
- (e) PCB

6. General Specification:

- (a) Operating Temp. : -40°C to +105°C (Including self - temperature rise).
- (b) Storage Temp. : -40°C to +125°C (on board).
- (c) Irms. : Based on temperature rise (ΔT : 40°C) Max.
- (d) Storage Condition (Component in its packaging)
 - i) Temperature: Less than 40°C
 - ii) Humidity : 60% RH

NOTE: Specifications subject to change without notice. Please check our website for latest information.

7. Electrical Characteristics:

Part Number	Inductance (μH)±30% (1-4)(2-3)	Test Frequency (Hz)	DCR (Ω)Typ. (1-4)(2-3)	Rated Current (A) Max.	L Stray. (nH) Typ.	V _{test} (VDC) 2s
WAE L445R0-RK-10	5.00	0.1V/100K	0.06	1.20	40.0	250
WAE L46110-RJ-10	11.0	0.1V/100K	0.08	1.00	50.0	250
WAE L46250-RK-10	25.0	0.1V/100K	0.11	1.00	60.0	250
WAE L46510-RH-10	51.0	0.1V/100K	0.30	0.80	70.0	250

8. Characteristics Curves:

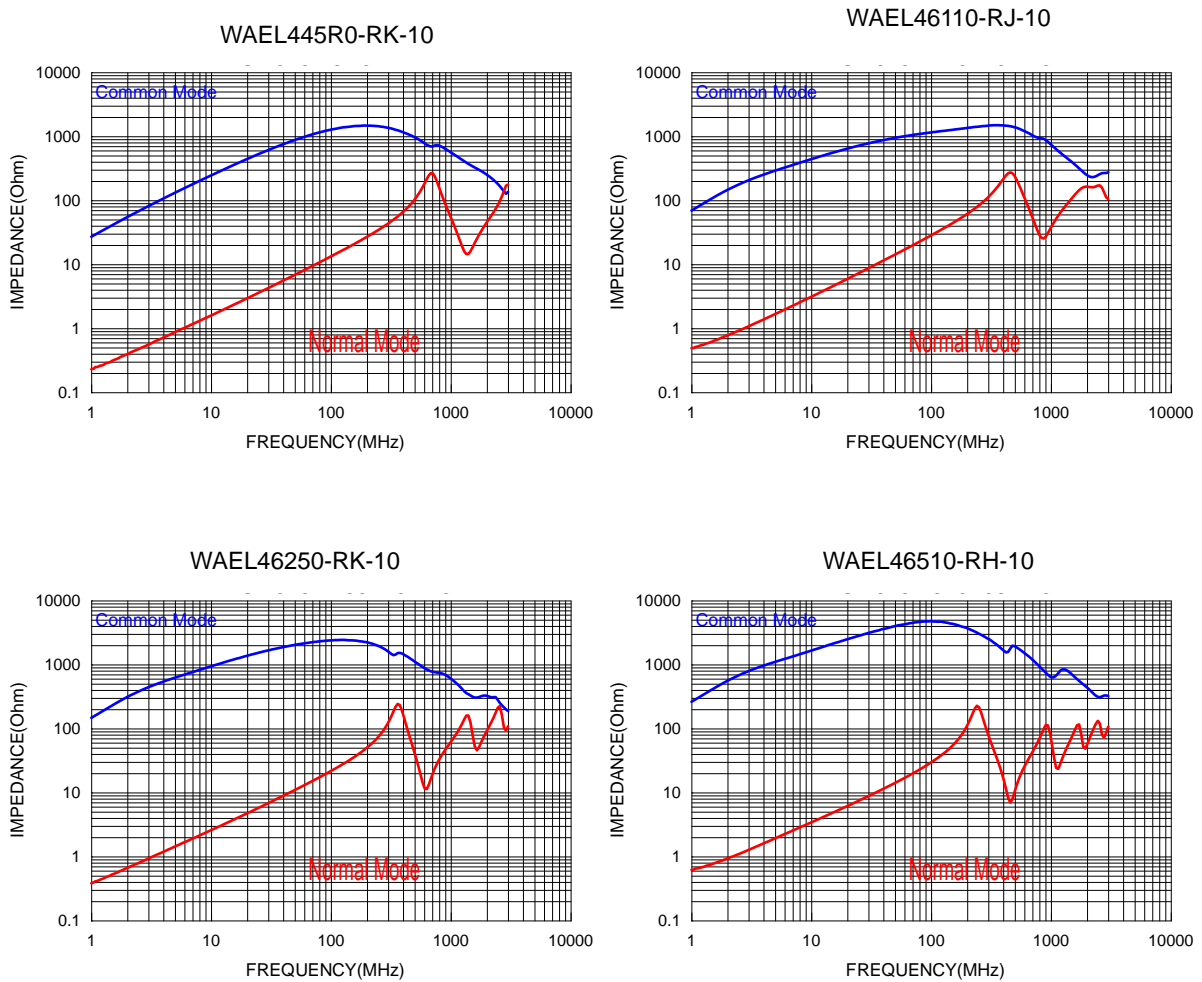

NOTE: Specifications subject to change without notice. Please check our website for latest information.



9. Soldering:

Mildly activated rosin fluxes are preferred. Our terminations are suitable for all re-flow soldering systems. If hand soldering cannot be avoided, the preferred technique is the utilization of hot air soldering tools.

9-1 Solder Re-flow

Recommended temperature profiles for re-flow soldering in Figure 1.

9-2 Soldering Iron (Figure 2)

Products attachment with soldering iron is discouraged due to the inherent process control limitations. In the event that a soldering iron must be employed the following precautions are recommended.

Note :

- a) Preheat circuit and products to 150°C.
- b) 350°C tip temperature (Max.)
- c) Never contact the ceramic with the iron tip
- d) 1.0mm tip diameter (Max.)
- e) Use a 20 watt soldering iron with tip diameter of 1.0mm
- f) Limit soldering time to 4~5 sec.

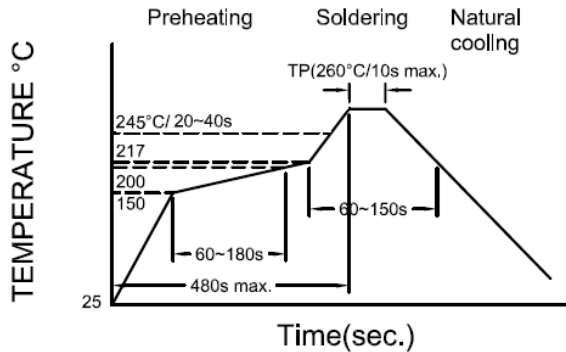

Figure 1. : Re-flow Soldering time 3 times Max.

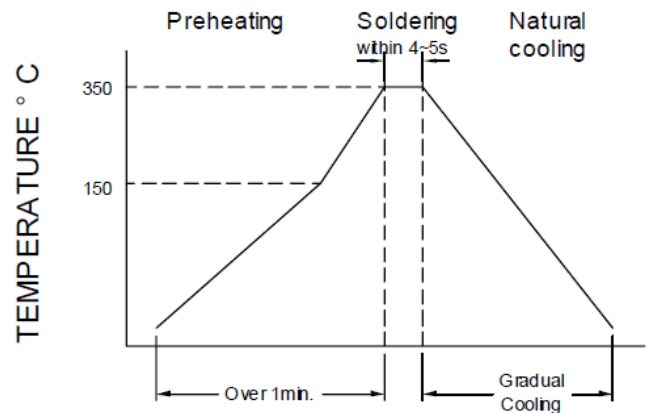

Figure 2. : Iron Soldering time 1 times Max.

NOTE: Specifications subject to change without notice. Please check our website for latest information.



10. Packaging Information:

10-1 Reel Dimension

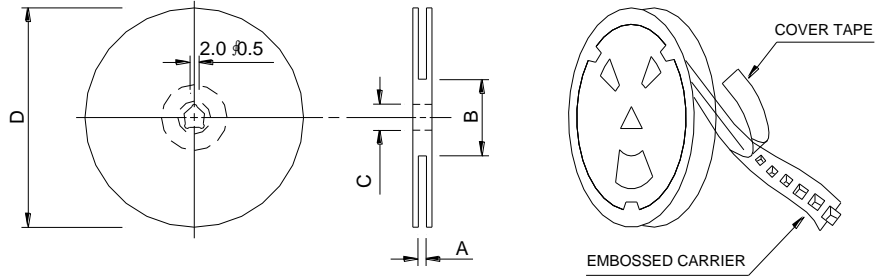

Type	A(mm)	B(mm)	C(mm)	D(mm)
13"x24mm	24.6±0.5	99.5±1.0	13.5±0.5	330±1.0

10-2 Tape Dimension

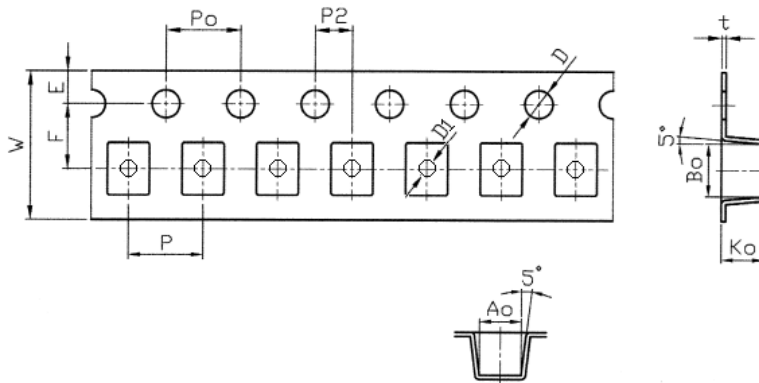

Size	P(mm)	Po(mm)	P2(mm)	Bo(mm)	Ao(mm)	Ko(mm)
	12.00±0.10	4.00±0.10	2.00±0.10	9.40±0.10	5.50±0.10	3.90±0.10
WAEI	D(mm)	D1(mm)	E(mm)	F(mm)	W(mm)	t(mm)
	1.50 +0.1/-0	1.50±0.10	1.75±0.10	11.5±0.10	24.0 +0.30/-0.1	0.35±0.05

NOTE: Specifications subject to change without notice. Please check our website for latest information.



10-3 Packaging Quantity

Chip Size	WAEL
Chip/Reel	1000

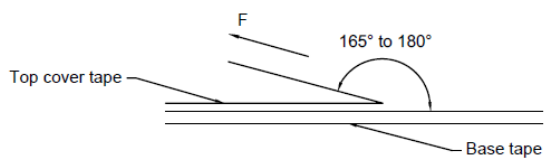
10-4 Tearing Off Force

The force for tearing off cover tape is 10 to 130 grams in the arrow direction under the following conditions.

Room Temp. (°C)	Room Humidity (%)	Room atm (hPa)	Tearing Speed mm/min
5~35	45~85	860~1060	300

Application Notice:**1. Storage Conditions:**

To maintain the solderability of terminal electrodes:

- a) Recommended products should be used within 12 months from the time of delivery.
- b) The packaging material should be kept where no chlorine or sulfur exists in the air.

2. Transportation:

- a) Products should be handled with care to avoid damage or contamination from perspiration and skin oils.
- b) Vacuum pick up is strongly recommended for individual components.
- c) Bulk handling should ensure that abrasion and mechanical shock are minimized.

NOTE: Specifications subject to change without notice. Please check our website for latest information.