

1. Part No. Expression:

**SPS252012H1R0YF**

(a)            (b)    (c) (d) (e) (f)

- (a) Series Code
- (b) Dimension Code
- (c) Material Code
- (d) Inductance Code
- (e) Tolerance Code
- (f) RoHS Compliant

2. Configuration & Dimensions : (Unit: mm)

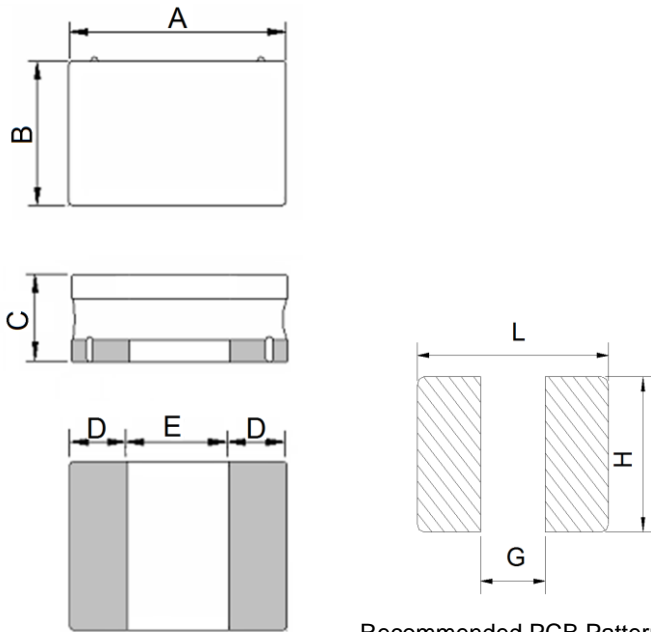

Recommended PCB Pattern

Unit : mm

A	B	C	D	E	L	G	H
2.50 ± 0.2	2.00 ± 0.2	1.20 Max.	0.85 Ref.	0.80 Ref.	2.70 Ref.	0.80 Ref.	2.20 Ref.

3. Schematic



NOTE: Specifications subject to change without notice. Please check our website for latest information.



4. Material List

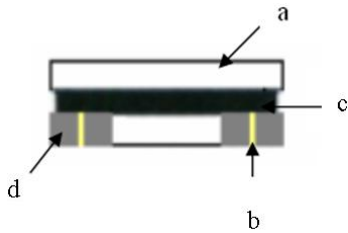

- (a) Core
- (b) Wire
- (c) Glue
- (d) Terminal

Void appearance tolerance limit & size of voids occurring to coating resin is specified below.

Appearance of exposed wire tolerance limit:

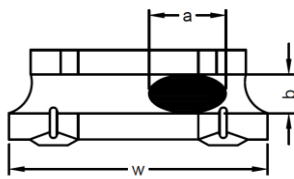

1. Width direction (dimension a) : Acceptable when  $a \leq w/2$ ;  
Nonconforming when  $a > w/2$
2. Length direction (dimension b): Dimension b is not specified
3. The total area of exposed wire occurring to each sides is not greater than 50% of coating resin area and is acceptable

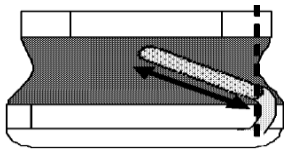

External appearance criterion for exposed wire

Exposed end of the winding wire at the secondary side should be 2mm and below.

5. General Specification:

- (a) Operating Temp. : -40°C to +125°C (Inclusive of coil temp rise).
- (b) Storage Temp. : -40°C to +125°C (on board).
- (c) Heat Rated Current (Irms) will cause the coil temperature rise approximately  $\Delta t$  of 40°C.
- (d) Saturation Current (Isat) will cause L0 to drop approximately 30%.
- (e) Storage condition (component in its packaging)
  - i) Temperature: Less than 40°C
  - ii) Humidity : 60% RH

NOTE: Specifications subject to change without notice. Please check our website for latest information.



## 6. Electrical Characteristics

Part No.	Inductance ( $\mu$ H)	Test Frequency (Hz)	DCR ( $\Omega$ ) $\pm 20\%$	Isat (A) Typ.	Isat (A) Max.	Irms (A) Typ.	Irms (A) Max.
SPS252012H1R0YF	1.00	0.1V/1M	0.073	2.80	2.24	2.20	1.76
SPS252012H1R5YF	1.50	0.1V/1M	0.100	2.20	1.76	1.86	1.48
SPS252012H2R2MF	2.20	0.1V/1M	0.129	1.80	1.44	1.70	1.36
SPS252012H3R3MF	3.30	0.1V/1M	0.220	1.30	1.04	1.20	0.96
SPS252012H4R7MF	4.70	0.1V/1M	0.290	1.10	0.88	1.04	0.83
SPS252012H6R8MF	6.80	0.1V/1M	0.370	0.94	0.75	0.94	0.75
SPS252012H100MF	10.0	0.1V/1M	0.570	0.82	0.65	0.84	0.60
SPS252012H150MF	15.0	0.1V/1M	0.835	0.70	0.60	0.50	0.45
SPS252012H220MF	22.0	0.1V/1M	1.200	0.60	0.55	0.45	0.40

### Notes:

(a) Tolerance Code: M =  $\pm 20\%$ ; Y =  $\pm 30\%$ .

(b) At all times, the current supplied to the product should not exceed Isat Max. value.

NOTE: Specifications subject to change without notice. Please check our website for latest information.



7. Characteristics Curves

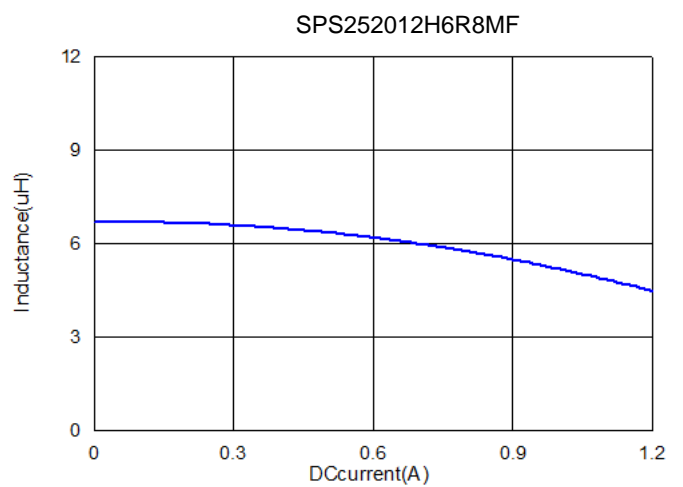
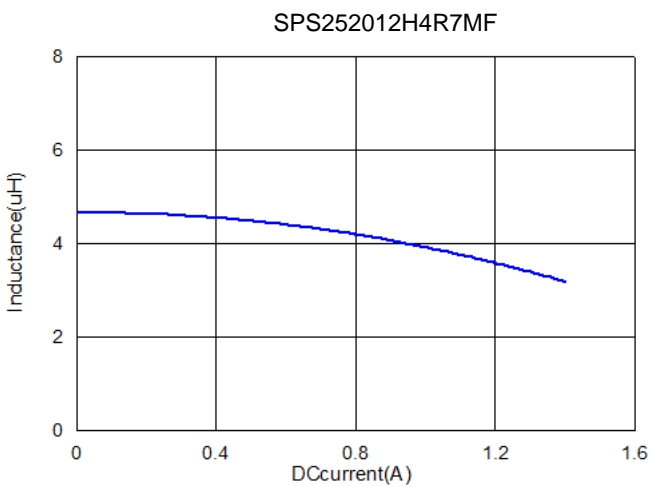
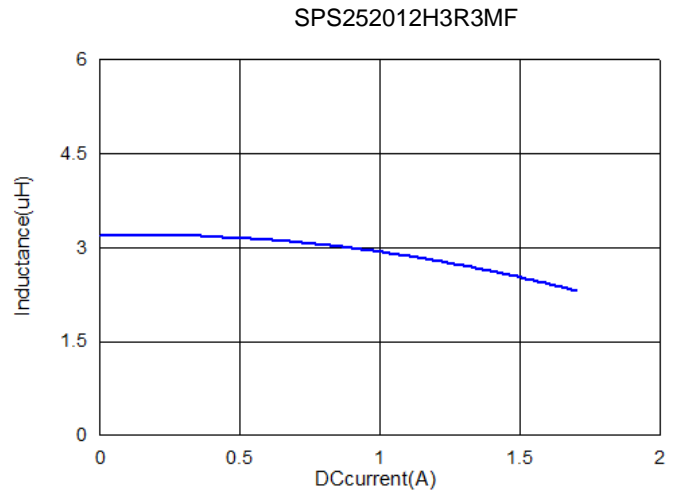
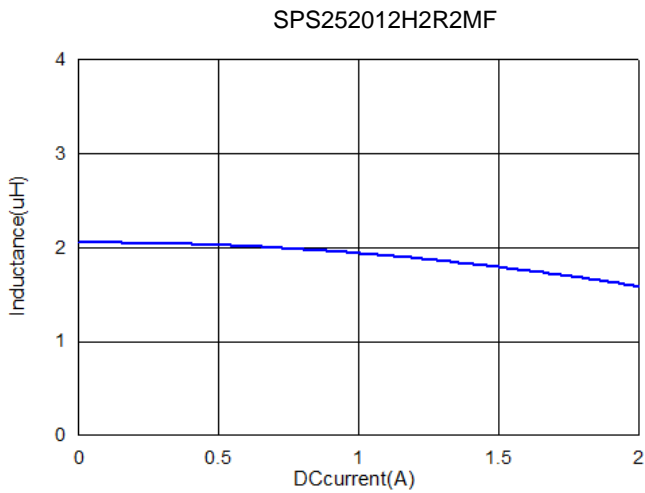
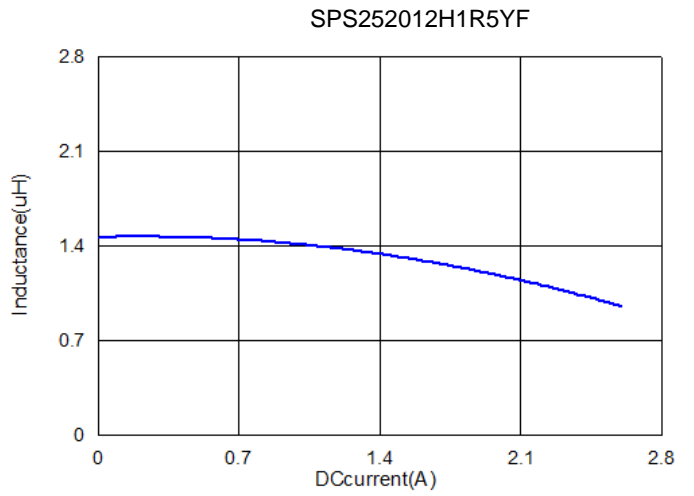
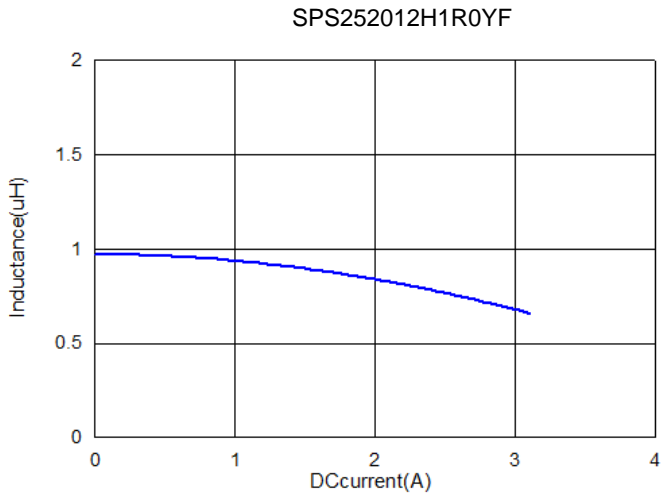

NOTE: Specifications subject to change without notice. Please check our website for latest information.



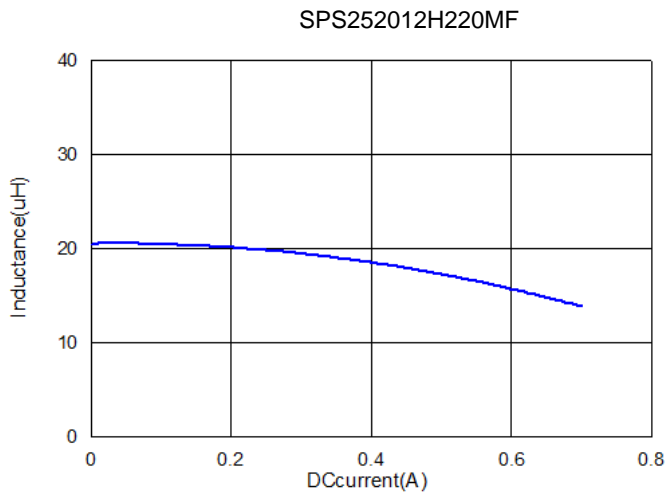
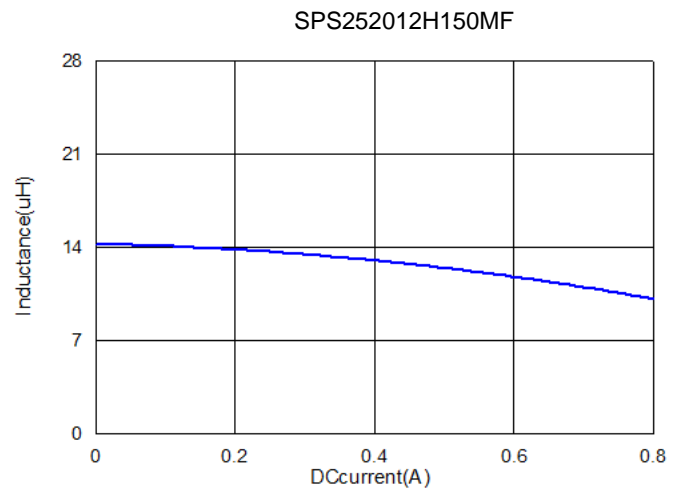
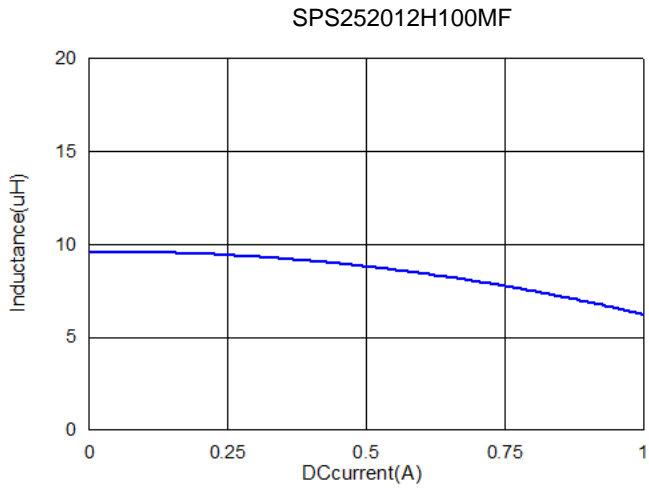

NOTE: Specifications subject to change without notice. Please check our website for latest information.



**8. Soldering**

Mildly activated rosin fluxes are preferred. The terminations are suitable for all wave and re-flow soldering systems. If hand soldering cannot be avoided, the preferred technique is the utilization of hot air soldering tools.

**8-1 Solder Re-flow:**

Recommended temperature profiles for re-flow soldering in Figure 1.

**8-2 Soldering Iron (Figure 2):**

Products attachment with soldering iron is discouraged due to the inherent process control limitations. In the event that a soldering iron must be employed the following precautions are recommended.

Note :

- a) Preheat circuit and products to 150°C.
- b) 355°C tip temperature (Max.)
- c) Never contact the ceramic with the iron tip
- d) 1.0mm tip diameter ( Max.)
- e) Use a 20 watt soldering iron with tip diameter of 1.0mm
- f) Limit soldering time to 4~5 secs.

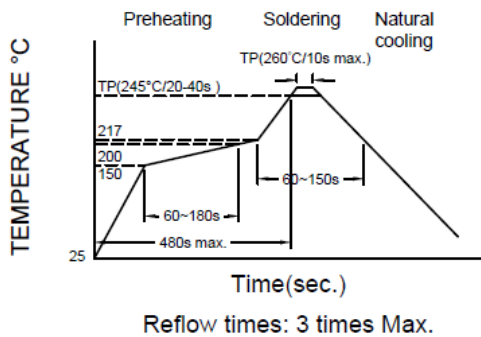

Fig.1

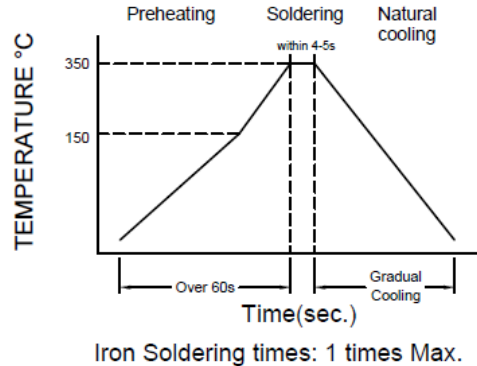

Fig.2

NOTE: Specifications subject to change without notice. Please check our website for latest information.



9. Packaging Information

9-1. Reel Dimension

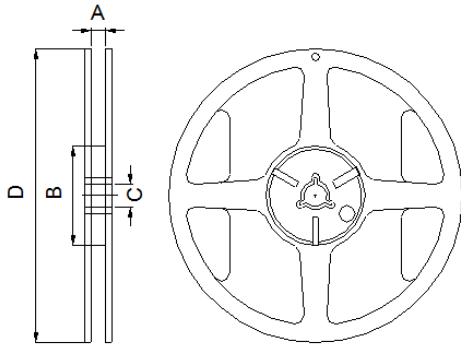

Type	A (mm)	B (mm)	C (mm)	D (mm)
7" x 8mm	8.4 ± 1.0	50 Min.	13.0 ± 0.8	178.0± 2.0

9-2. Tape Dimension

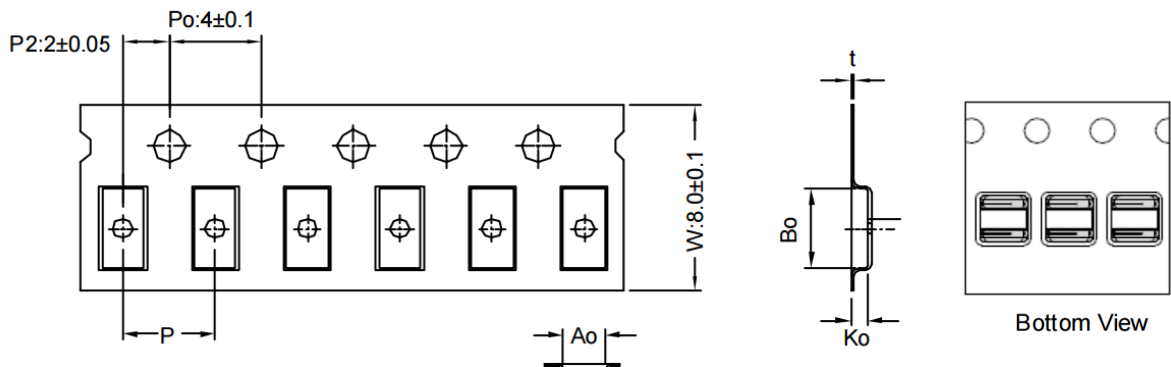

Series	Bo(mm)	Ao(mm)	Ko(mm)	P(mm)	t(mm)
SPS252012	3.10±0.10	2.45±0.10	1.40±0.10	4.00±0.05	0.23±0.05

9-3. Packaging Quantity

Size	SPS252012
Chip/ Reel	2000

NOTE: Specifications subject to change without notice. Please check our website for latest information.

9-4. Tearing Off Force

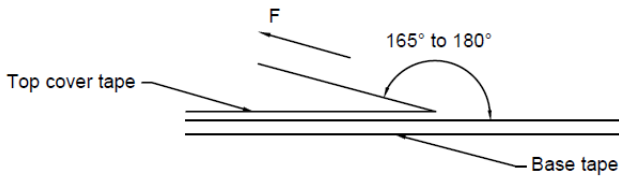

The force for tearing off cover tape is 15 to 80 grams in the arrow direction under the following conditions.

Room Temp (°C)	Room Humidity (%)	Room atm (hPa)	Tearing Speed (mm/min)
5 - 35	45 - 85	860 - 1060	300

**Application Notice:**

1. Storage Conditions:

To maintain the solderability of terminal electrodes:

- a) Recommended products should be used within 12 months from the time of delivery.
- b) The packaging material should be kept where no chlorine or sulfur exists in the air.

2. Transportation:

- a) Products should be handled with care to avoid damage or contamination from perspiration and skin oils.
- b) Vacuum pick up is strongly recommended for individual components.
- c) Bulk handling should ensure that abrasion and mechanical shock are minimized.

NOTE: Specifications subject to change without notice. Please check our website for latest information.

