

1. Part No. Expression:

SPA201610RAR24M

(a) (b) (c) (d) (e)

- a) Series Code
- b) Dimension Code
- c) Type Code
- d) Inductance Code
- e) Tolerance Code

2. Configuration & Dimensions:- (Unit: mm)

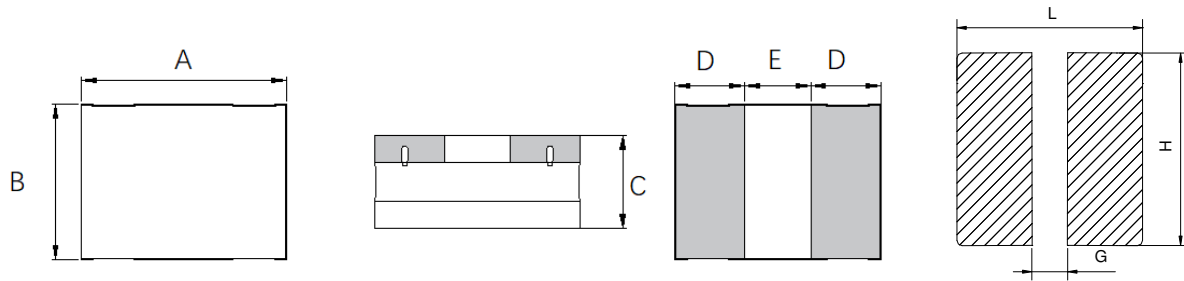

Recommended PC Board Pattern

A	B	C	D	E	L	G	H
2.00±0.20	1.60±0.20	0.90±0.10	0.65±0.20	0.75±0.20	2.3 Ref	0.6 Ref	1.9 Ref

3. Material List:

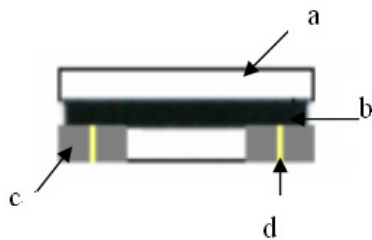

- (a) Core
- (b) Glue
- (c) Terminal
- (d) Wire

NOTE: Specifications subject to change without notice. Please check our website for latest information.



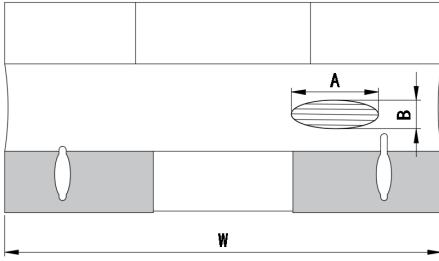

Appearance of exposed wire tolerance limit:

1. Width direction (dimension a) : Acceptable when $a \leq w/2$
Non-acceptable when $a > w/2$
2. Length direction (dimension b) : Dimension b is not specified.
3. The total area of exposed wire occurring to each sides is not greater than 50% of coating resin area, and is acceptable.

4. General Specification:

- (a) Operating Temp: -40°C to +125°C (including self-temperature rise)
- (b) Storage Temp: -40°C to +125°C (on board)
- (c) Heat rated current (I_{rms}) will cause coil temperature to rise approximately ΔT of 40°C.
- (d) Saturation current (I_{sat}) will cause L₀ to drop approximately 30%.
- (e) Storage condition (component in its packaging)
 - i) Temperature: Less than 40°C
 - ii) Humidity: 60% RH

5. Electrical Characteristics:

Part Number	Inductance (uH)	Test Frequency (Hz)	I _{rms} (A) Typ.	I _{rms} (A) Max.	I _{sat} (A) Typ.	I _{sat} (A) Max.	DCR (Ω) Typ.	DCR (Ω) Max.
SPA201610RAR24M	0.24	1.0V/ 1M	5.60	5.00	7.00	6.00	0.021	0.0252
SPA201610RAR33M	0.33	1.0V/ 1M	5.10	4.60	5.50	5.00	0.028	0.0336
SPA201610RAR47M	0.47	1.0V/ 1M	4.50	4.00	4.80	4.40	0.041	0.0492
SPA201610RAR68M	0.68	1.0V/ 1M	3.80	3.40	4.00	3.50	0.055	0.066
SPA201610RA1R0M	1.00	1.0V/ 1M	3.10	2.80	3.60	3.10	0.075	0.090
SPA201610RA1R5M	1.50	1.0V/ 1M	2.40	2.10	3.10	2.70	0.115	0.138
SPA201610RA2R2M	2.20	1.0V/ 1M	1.90	1.60	2.40	2.10	0.170	0.204
SPA201610RA3R3M	3.30	1.0V/ 1M	1.50	1.30	1.60	1.30	0.190	0.218
SPA201610RA4R7M	4.70	1.0V/ 1M	1.30	1.10	1.40	1.20	0.320	0.384

NOTE: Specifications subject to change without notice. Please check our website for latest information.



6. Characteristics Curves:

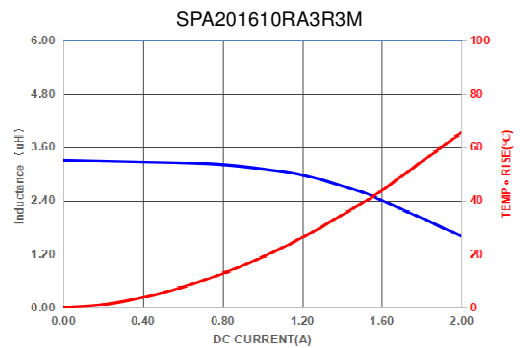
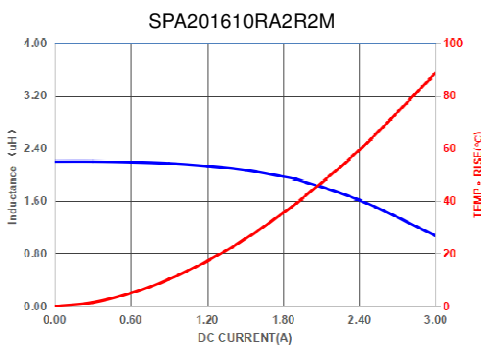
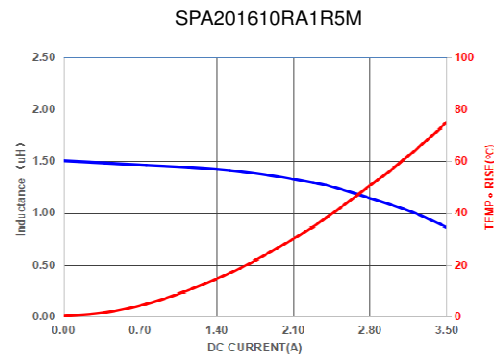
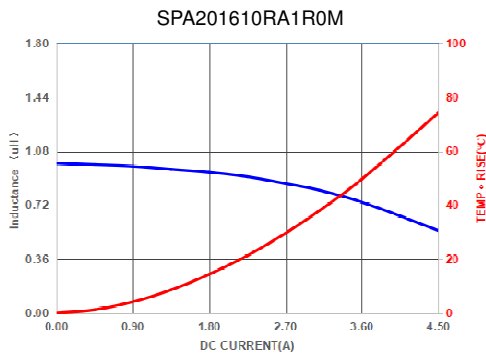
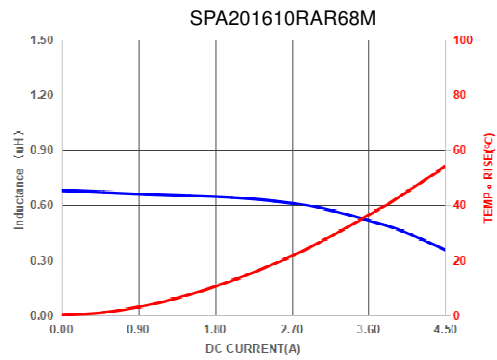
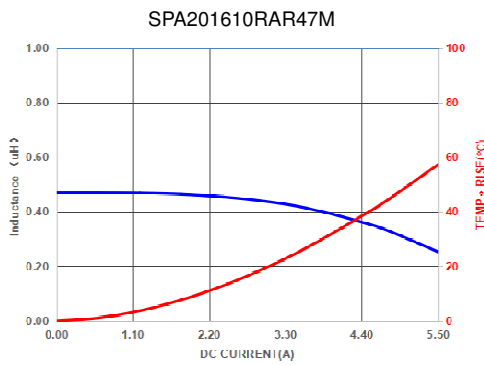
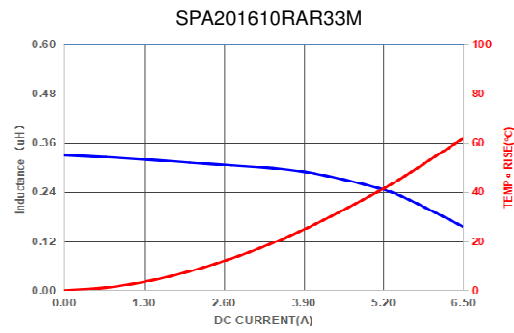
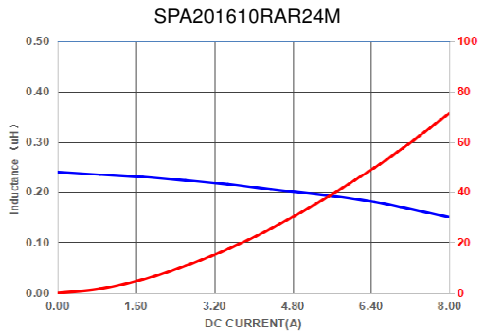

NOTE: Specifications subject to change without notice. Please check our website for latest information.



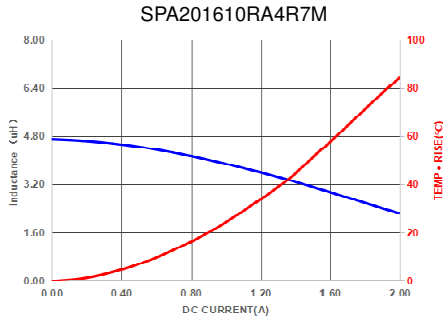

7. Soldering and Mounting:

Mildly activated rosin fluxes are preferred. The minimum amount of solder can lead to damage from the stresses caused by the difference in coefficients of expansion between solder, chip and substrate. Our terminations are suitable for all re-flow soldering systems. If hand soldering cannot be avoided, the preferred technique is the utilization of hot air.

7-1 Solder Re-flow:

Recommended temperature profiles for re-flow soldering in Figure 1.

7-2 Soldering Iron (Figure 2):

Products attachment with soldering iron is discouraged due to the inherent process control limitations. In the event that a soldering iron must be employed the following precautions are recommended.

Note:

- a) Preheat circuit and products to 150°C.
- b) 355°C tip temperature (Max.)
- c) Never contact the ceramic with the iron tip.
- d) 1.0mm tip diameter (Max.)
- e) Use a 20 watt soldering iron with tip diameter of 1.0mm.
- f) Limit soldering time to 4~5 secs.

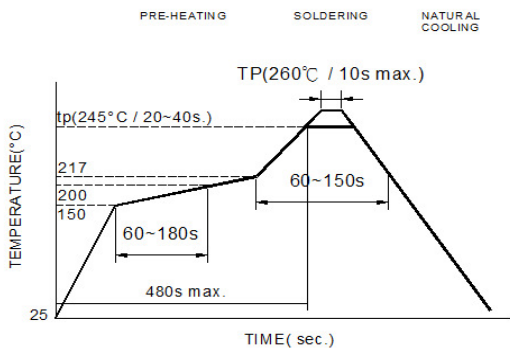

Reflow times: 3 times max.

Fig.1

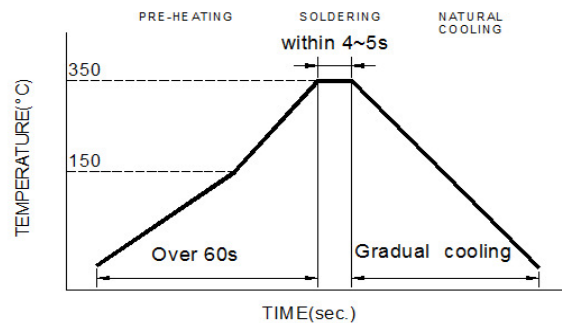

Iron Soldering times: 1 times max.

Fig.2

NOTE: Specifications subject to change without notice. Please check our website for latest information.

8. Packaging Information:

8-1 Reel Dimension

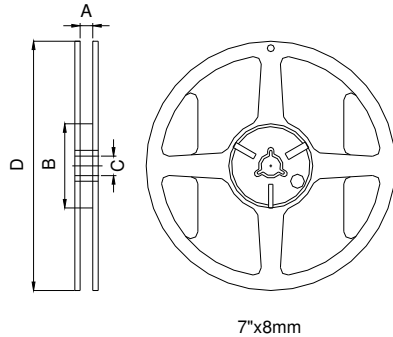

Type	A(mm)	B(mm)	C(mm)	D(mm)
7"x8mm	8.4±1.0	50 Min.	13±0.8	178±2

8-2 Tape Dimension

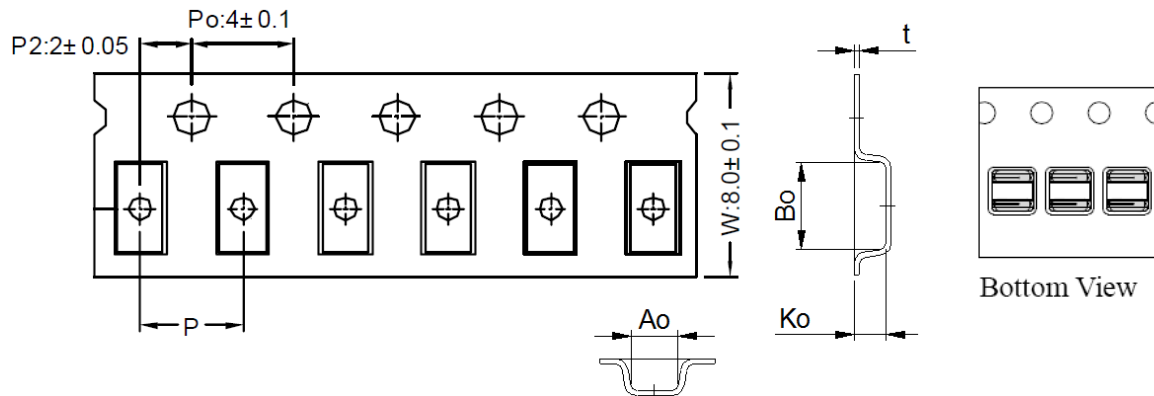

Series	Size	Bo(mm)	Ao(mm)	Ko(mm)	P(mm)	t(mm)
SPA	201610	2.5±0.1	2.0±0.1	1.20±0.1	4.0±0.1	0.22±0.05

8-3 Packaging Quantity

Chip size	201610
Chip / Reel	2000

NOTE: Specifications subject to change without notice. Please check our website for latest information.

8-4 Tearing Off Force

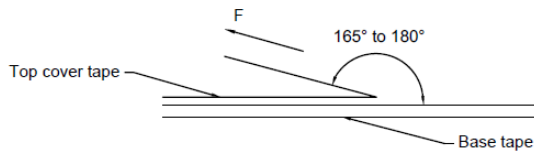

The force for tearing off cover tape is 10 to 100 grams in the arrow direction under the following conditions

Room Temp. (°C)	Room Humidity (%)	Room atm (hPa)	Tearing Speed mm/min
5~35	45~85	860~1060	300

Application Notice:

1. Storage Conditions:

To maintain the solderability of terminal electrodes:

- a) Recommended products should be used within 12 months from the time of delivery.
- b) The packaging material should be kept where no chlorine or sulfur exists in the air.

2. Transportation:

- a) Products should be handled with care to avoid damage or contamination from perspiration and skin oils.
- b) Vacuum pick up is strongly recommended for individual components.
- c) Bulk handling should ensure that abrasion and mechanical shock are minimized.

NOTE: Specifications subject to change without notice. Please check our website for latest information.

