

1. Part No. Expression

PNS40181R0YWF

(a) (b) (c) (d)(e)(f)

- | | |
|---------------------|--------------------|
| (a) Series Code | (d) Tolerance Code |
| (b) Dimension Code | (e) Special Code |
| (c) Inductance Code | (f) Packaging Code |

2. Configuration & Dimensions: (Unit:- mm)

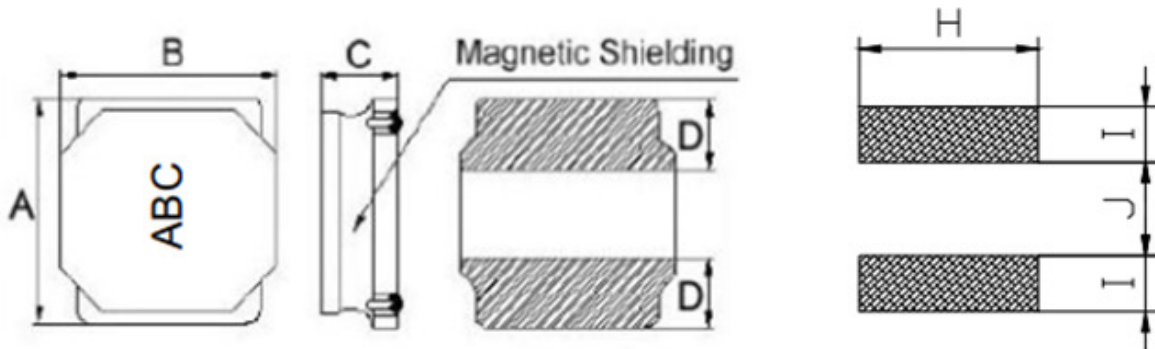

Recommended Land Pattern

Note: 1. Solder paste thickness at 0.12mm and above is recommended.

A	B	C	D	H	I	J
4.0±0.2	4.0±0.2	1.8+0.2/-0.3	1.3 Ref	3.7 Ref	1.2 Ref	1.6 Ref

3. Schematic

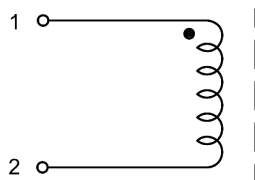

NOTE: Specifications subject to change without notice. Please check our website for latest information.

4. Material List

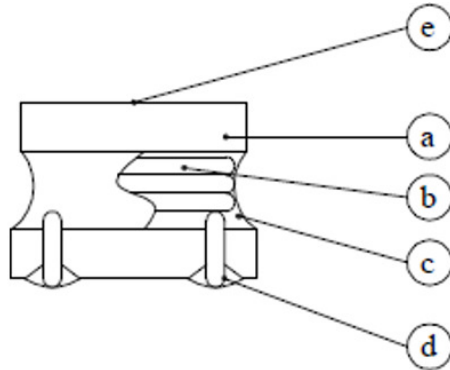

- a) Core
- b) Wire
- c) Adhesive
- d) Terminal
- e) Ink

5. General Specifications

- (a) Operating Temp. : -40°C to +125°C (Including self-temperature rise).
- (b) Storage Temp. : -40°C to +125°C.
- (c) Irms: Based on temperature rise (ΔT : 40°C Typ).
- (d) Isat: Based on inductance change ($\Delta L/L_0$: 30% Typ).
- (e) Storage condition (component in its packaging)
 - i) Temperature: Less than 40°C
 - ii) Humidity: 60% RH

NOTE: Specifications subject to change without notice. Please check our website for latest information.

6. Electrical Characteristics

Part Number	Inductance (uH)	Test Freq. (Hz)	DCR (mΩ) Max	Isat (A) Typ	Isat (A) Max	Irms (A) Typ	Irms (A) Max	Marking
PNS40181R0YWF	1.0±30%	1V/100K	38.4	4.10	3.69	2.80	2.52	1R0
PNS40181R5YWF	1.5±30%	1V/100K	48	3.30	2.97	2.60	2.34	1R5
PNS40182R2MWF	2.2±20%	1V/100K	72	2.80	2.52	2.50	2.25	2R2
PNS40183R3MWF	3.3±20%	1V/100K	84	2.20	1.98	2.10	1.89	3R3
PNS40184R7MWF	4.7±20%	1V/100K	108	2.00	1.80	1.70	1.53	4R7
PNS40186R8MWF	6.8±20%	1V/100K	143	1.60	1.44	1.50	1.35	6R8
PNS4018100MWF	10±20%	1V/100K	228	1.40	1.26	1.20	1.08	100
PNS4018150MWF	15±20%	1V/100K	300	1.00	0.90	1.00	0.90	150
PNS4018220MWF	22±20%	1V/100K	468	0.9	0.81	0.85	0.76	220
PNS4018330MWF	33±20%	1V/100K	636	0.8	0.72	0.70	0.63	330
PNS4018470MWF	47±20%	1V/100K	864	0.70	0.63	0.56	0.50	470
PNS4018680MWF	68±20%	1V/100K	1200	0.56	0.50	0.45	0.40	680
PNS4018101MWF	100±20%	1V/100K	1800	0.46	0.41	0.34	0.31	101
PNS4018151MWF	150±20%	1V/100K	3000	0.35	0.31	0.25	0.22	151
PNS4018221MWF	220±20%	1V/100K	4800	0.28	0.25	0.20	0.17	221

Tolerance: Y = ±30%; M = ±20%

NOTE: Specifications subject to change without notice. Please check our website for latest information.



7. Soldering and Mounting

Mildly activated rosin fluxes are preferred. Our terminations are suitable for all re-flow soldering systems. If hand soldering cannot be avoided, the preferred technique is the utilization of hot air soldering tools.

7-1 Solder Re-flow

Recommended temperature profiles for re-flow soldering in Figure 1.

7-2 Soldering Iron (Figure 2)

Products attachment with soldering iron is discouraged due to the inherent process control limitations. In the event that a soldering iron must be employed the following precautions are recommended.

Note:

- a) Preheat circuit and products to 150°C.
- b) 350°C tip temperature (Max.)
- c) Never contact the ceramic with the iron tip
- d) 1.0mm tip diameter (Max.)
- e) Use a 20 Watt soldering iron with tip diameter of 1.0mm.
- f) Limit soldering time to 4~5 sec.

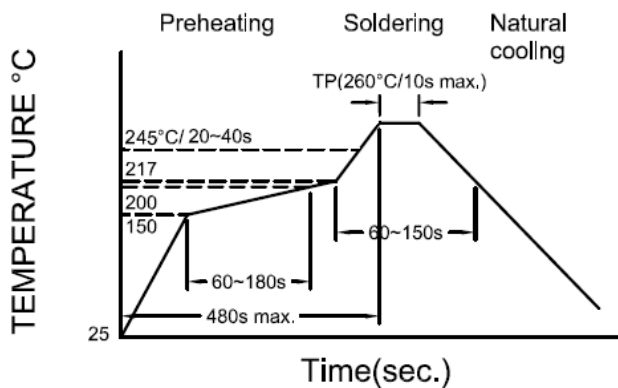

Figure 1: Re-flow Soldering Time 3 times Max.

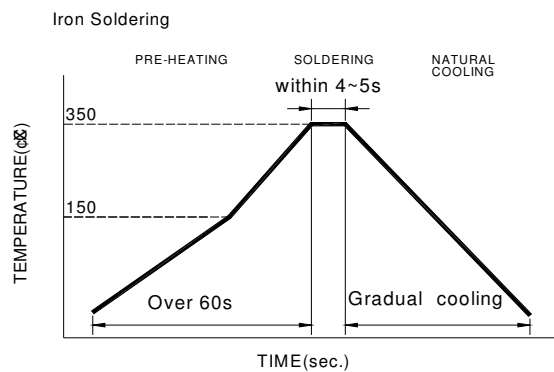

Figure 2: Iron Soldering Time 1 times Max.

NOTE: Specifications subject to change without notice. Please check our website for latest information.



8. Packaging Information

8-1. Reel Dimension

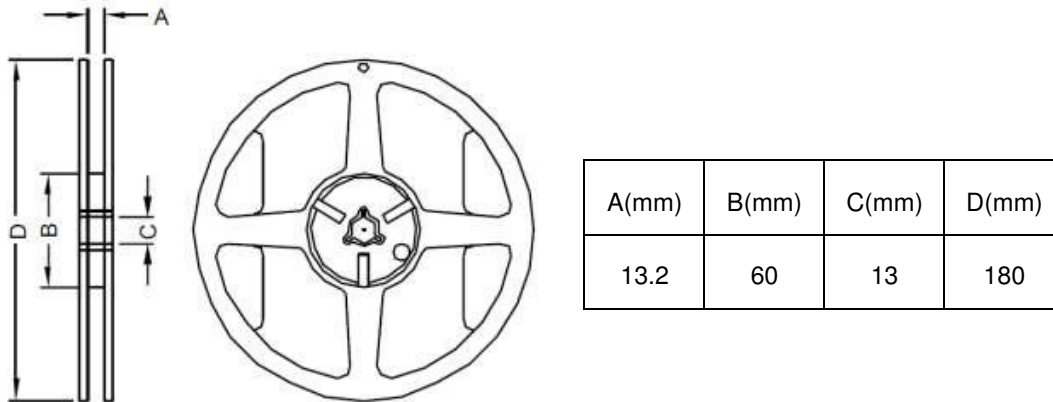

8-2. Tape Dimension

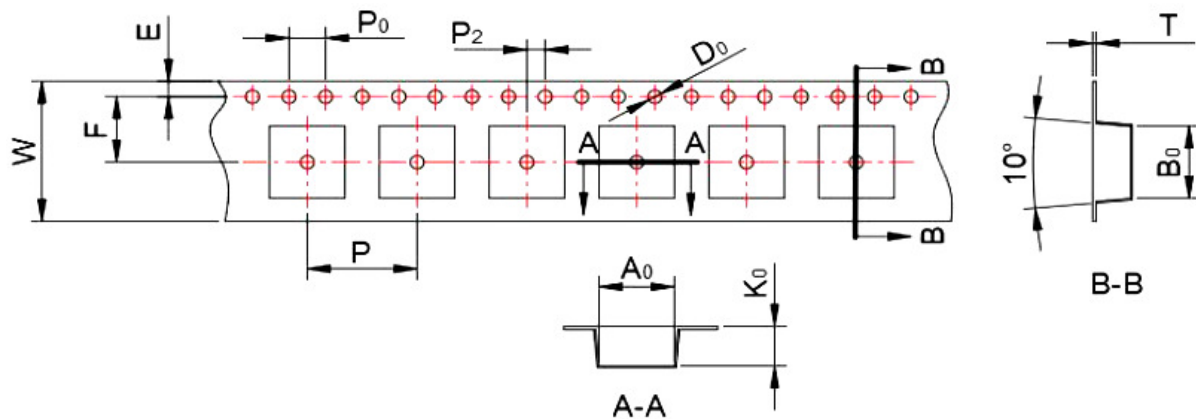

W(mm)	Ao(mm)	B0(mm)	Ko(mm)	P(mm)	F(mm)	E(mm)	D0(mm)	P0(mm)	P2(mm)	T(mm)
12	4.2	4.2	2.1	8.0	5.5	1.75	1.5	4.0	2.0	0.3

NOTE: Specifications subject to change without notice. Please check our website for latest information.

8-3 Packaging Quantity

Chip Size	PNS4018
Chip/Reel	3000
Inner Box	12000
Outer Box	24000

8-4 Tearing Off Force

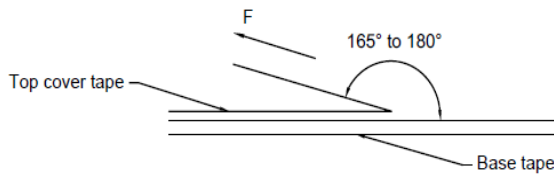

The force for tearing off cover tape is 10 to 130 grams in the arrow direction under the following conditions.

Room Temp. (°C)	Room Humidity (%)	Room atm (hPa)	Tearing Speed mm/min
5~35	45~85	860~1060	300

Application Notice:

1. Storage Conditions:

To maintain the solderability of terminal electrodes:

- a) Recommended products should be used within 12 months from the time of delivery.
- b) The packaging material should be kept where no chlorine or sulfur exists in the air.

2. Transportation:

- a) Products should be handled with care to avoid damage or contamination from perspiration and skin oils.
- b) Vacuum pick up is strongly recommended for individual components.
- c) Bulk handling should ensure that abrasion and mechanical shock are minimized.

NOTE: Specifications subject to change without notice. Please check our website for latest information.