

1. Part No. Expression:

P I M Q 3 2 2 5 1 2 A R 2 2 M N

(a) (b) (c) (d) (e) (f)

- (a) Series Code
- (b) Dimension Code
- (c) Type Code
- (d) Inductance Code
- (e) Tolerance Code
- (f) Special Code

2. Configuration & Dimensions (Unit: mm)

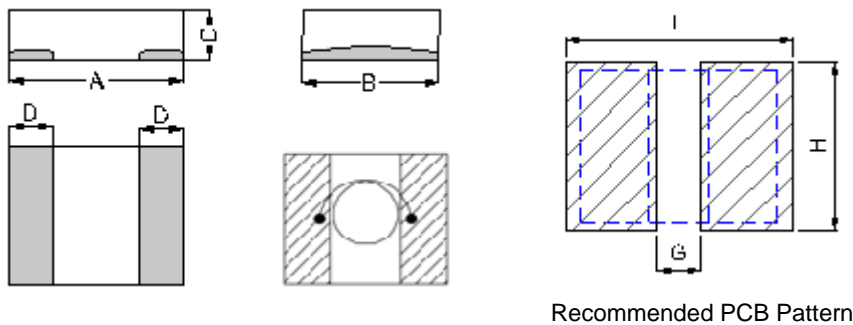

A(mm)	B(mm)	C(mm)	D(mm)	L(mm)	G(mm)	H(mm)
3.2±0.3	2.5±0.3	1.0±0.2	1.1±0.3	3.7 Ref	0.7 Ref	2.8 Ref

3. General Specification:

- (a) Reliability test complied to AEC-Q200 standard.
- (b) Operating Temp.: -55°C to +150°C (Inclusive of coil temp rise).
- (c) Storage Temp.: -55°C to +150°C (on board).
- (d) Heat Rated Current (I_{rms}) will cause the coil temperature rise approximately Δt of 40°C.
- (e) Saturation Current (I_{sat}) will cause L₀ to drop approximately 30%.
- (f) Storage condition (component in its packaging)
 - i) Temperature: -10°C to +40°C
 - ii) Humidity: 50~60% RH

NOTE: Specifications subject to change without notice. Please check our website for latest information.

4. Electrical Characteristics:

Part No.	Inductance @ 0A (μ H) $\pm 20\%$	I _{rms} (A) Typ	I _{rms} (A) Max	I _{sat} (A) Typ	I _{sat} (A) Max	DCR (m Ω) Typ	DCR (m Ω) Max
PIMQ322512AR22MN	0.22	9.5	9.0	9.3	8.7	7.4	8.5
PIMQ322512AR33MN	0.33	8.5	8.0	9.1	8.5	10.0	13.0
PIMQ322512AR47MN	0.47	7.0	6.5	8.2	7.4	16.0	19.2
PIMQ322512AR68MN	0.68	6.2	5.7	7.3	6.8	20.0	24.0
PIMQ322512A1R0MN	1.00	5.5	5.0	6.5	5.7	26.0	32.0
PIMQ322512A1R5MN	1.50	4.4	3.9	5.0	4.5	44.0	53.0
PIMQ322512A2R2MN	2.20	4.0	3.6	4.8	4.3	61.0	73.0
PIMQ322512A3R3MN	3.30	3.1	2.8	3.4	3.0	87.0	101.0
PIMQ322512A4R7MN	4.70	2.2	1.9	2.8	2.4	122.0	146.0

Note:

1. Test Frequency: 1.0V/100kHz
2. All test data referenced to 25°C ambient

NOTE: Specifications subject to change without notice. Please check our website for latest information.



5. Characteristics Curve

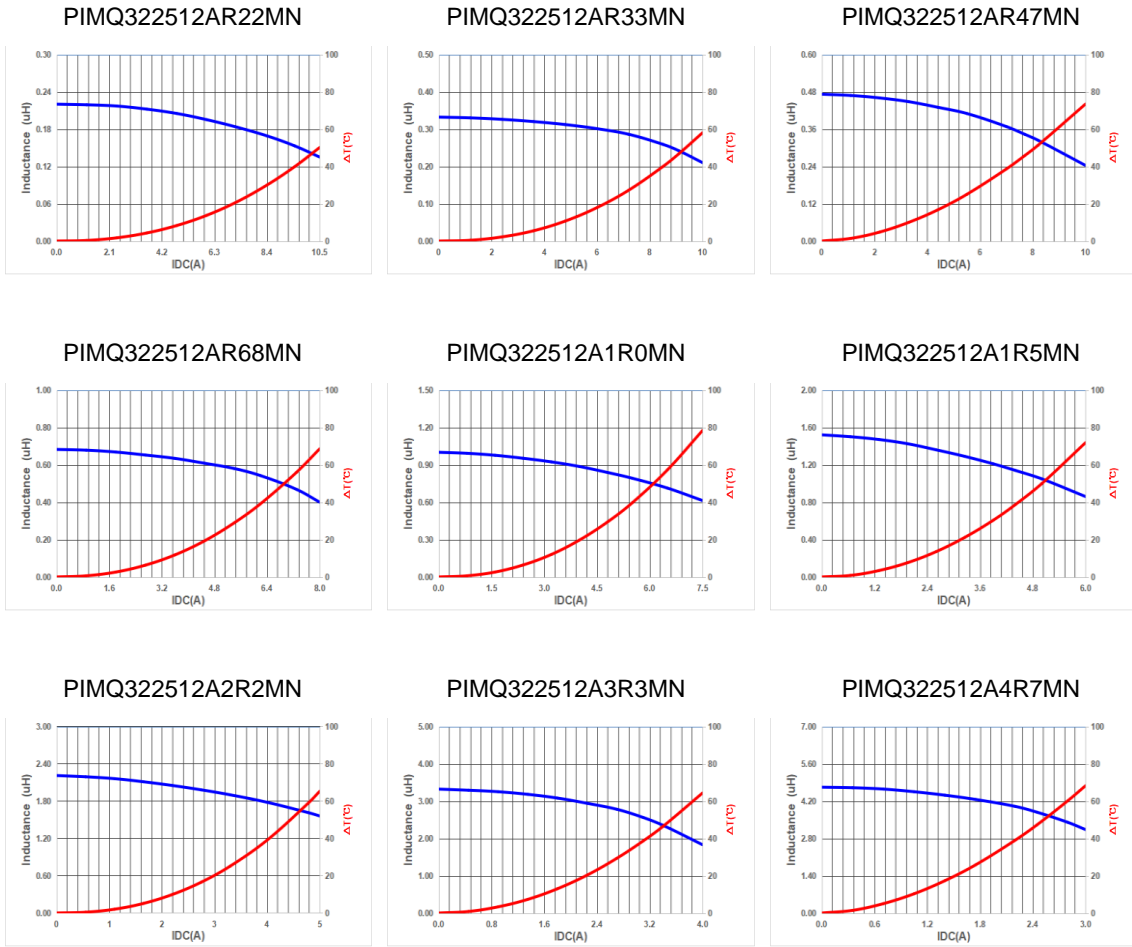

NOTE: Specifications subject to change without notice. Please check our website for latest information.



6. Soldering:

Mildly activated rosin fluxes are preferred. Our terminations are suitable for re-flow soldering systems. If hand soldering cannot be avoided, the preferred technique is the utilization of hot air soldering tools.

6-1 IR Soldering Reflow

Recommended temperature profiles for lead free re-flow soldering in Figure 1. Table 1.1 & 1.2 (J-STD-020E).

6-2 Iron Reflow (Figure 2)

Products attachment with soldering iron is discouraged due to the inherent process control limitations. In the event that a soldering iron must be employed the following precautions are recommended.

Note:

- a) Preheat circuit and products to 150°C.
- b) 280°C tip temperature (Max.)
- c) Never contact the ceramic with the iron tip.
- d) 1.0mm tip diameter (Max.)
- e) Use a 20 watt soldering iron with tip diameter of 1.0mm.
- f) Limit soldering time to 3 secs.

Fig.1 IR Soldering Reflow

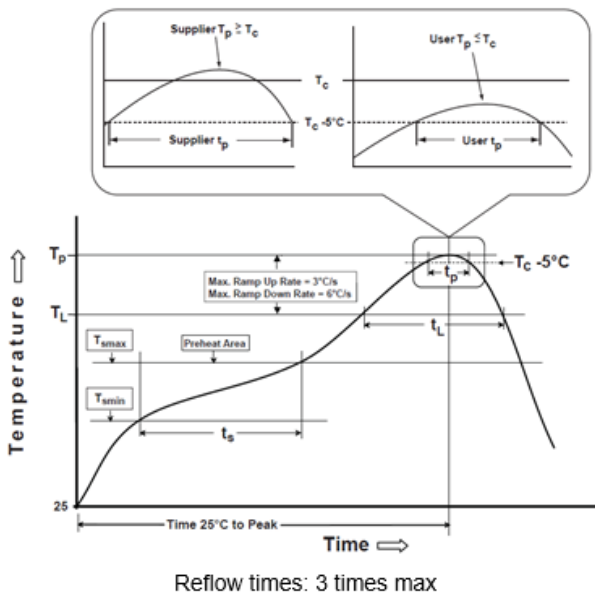
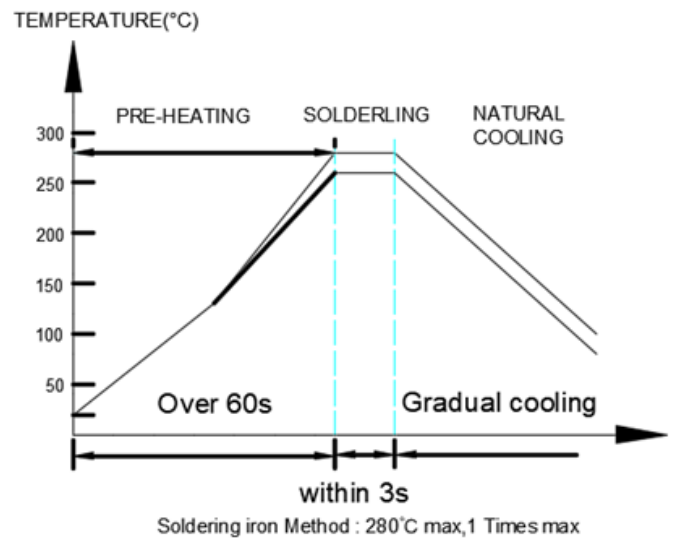

Fig.2 Iron soldering temperature profiles



NOTE: Specifications subject to change without notice. Please check our website for latest information.



Table1.1: Reflow Profiles

Profile Type:	Pb-Free Assembly
Preheat	
-Temperature Min (T_{smin})	150°C
-Temperature Max (T_{smax})	200°C
-Time(t_s) from (T_{smin} to T_{smax})	60-120seconds
Ramp-up rate (T_L to T_p)	3°C/second max.
Liquidus temperature (T_L)	217°C
Time(t_L)maintained above T_L	60-150 seconds
Classification temperature (T_c)	See Table (1.2)
Time(t_p) at $T_c - 5^\circ\text{C}$ (T_p should be equal to or less than T_c .)	< 30 seconds
Ramp-down rate (T_p to T_L)	6°C /second max.
Time 25°C to peak temperature	8 minutes max.

T_p: maximum peak package body temperature, **T_c**: the classification temperature.

For user (customer) **T_p** should be equal to or less than **T_c**.

Table 1.2: Package Thickness/Volume and Classification Temperature (T_c)

	Package Thickness	Volume mm ³ <350	Volume mm ³ 350-2000	Volume mm ³ >2000
PB-Free Assembly	<1.6mm	260°C	260°C	260°C
	1.6-2.5mm	260°C	250°C	245°C
	≥2.5mm	250°C	245°C	245°C

Reflow is referred to standard IPC/JEDEC J-STD-020E.

NOTE: Specifications subject to change without notice. Please check our website for latest information.

7. Packaging Information:

7-1. Reel Dimension (Unit : mm)

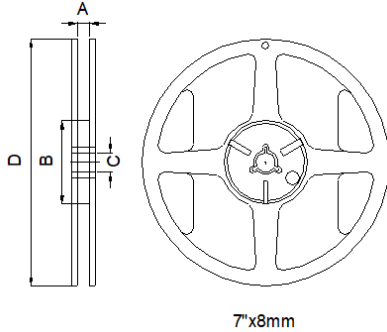

Type	A(mm)	B(mm)	C(mm)	D(mm)
7"x8mm	8.4+1.5/-0.0	50 min	13+5.5/-0.2	178±2.0

7-2. Tape Dimension (Unit : mm)

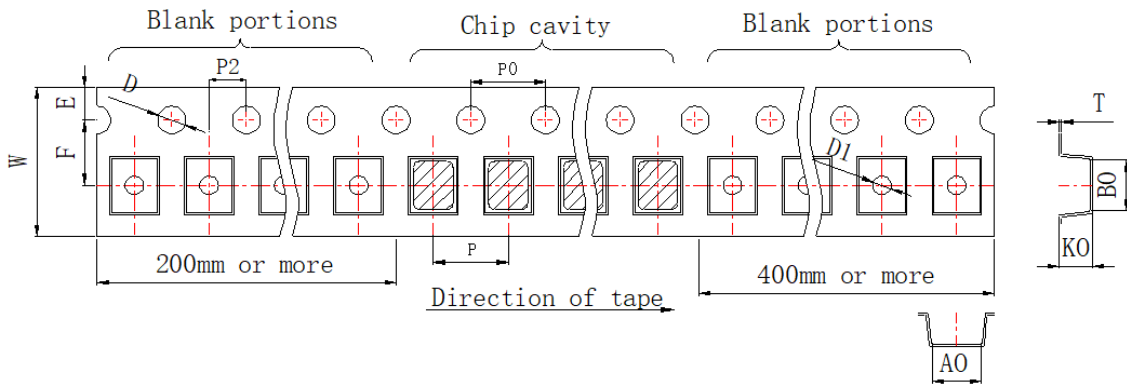

Series	B0(mm)	A0(mm)	K0(mm)	W(mm)	P(mm)
PIMQ322512A	3.6±0.1	2.9±0.1	1.4±0.1	8.0±0.1	4.0±0.1
P0(mm)	P2(mm)	E(mm)	F(mm)	T(mm)	D/D1(mm)
4.0±0.1	2.0±0.1	1.75±0.1	3.5±0.1	0.22±0.05	1.5+0.1/-0.0

NOTE: Specifications subject to change without notice. Please check our website for latest information.



7-3. Packaging Quantity

Size	PIMQ322512A
Chip/ Reel	2000

7-4. Tearing Off Force

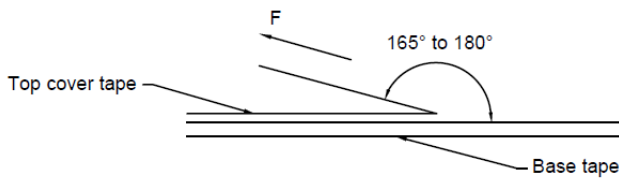

The force for tearing off cover tape is 10 to 100 grams in the arrow direction under the following conditions.

Room Temp (°C)	Room Humidity (%)	Room atm (hPa)	Tearing Speed (mm/min)
5 - 35	45 - 85	860 - 1060	300

Application Notice:

1. Storage Conditions:

To maintain the solderability of terminal electrodes:

- a) Recommended products should be used within 12 months from the time of delivery.
- b) The packaging material should be kept where no chlorine or sulfur exists in the air.

2. Transportation:

- a) Products should be handled with care to avoid damage or contamination from perspiration and skin oils.
- b) Vacuum pick up is strongly recommended for individual components.
- c) Bulk handling should ensure that abrasion and mechanical shock are minimized.

NOTE: Specifications subject to change without notice. Please check our website for latest information.