

1. Part No. Expression:

P I C Q 0 6 2 4 H R 1 0 Y F

(a) (b) (c) (d) (e)(f)

- a) Series Code
- b) Dimension Code
- c) Type Code
- d) Inductance Code
- e) Tolerance Code
- f) RoHS Compliant

2. Configuration & Dimensions:

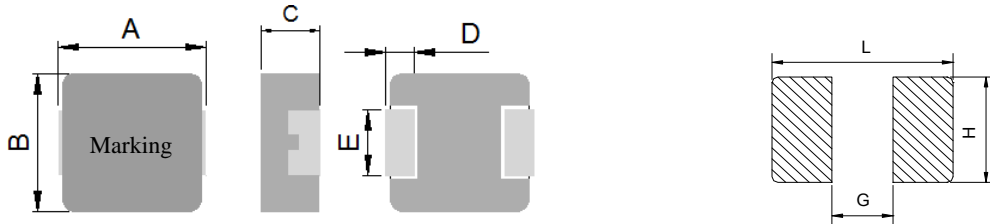

Recommended PC Board Pattern

Note:

1. The above PCB layout is for reference only.
2. Solder paste thickness of 0.15mm and above is recommended.
3. Marking : Top row – Inductance code, Bottom row – Year/World week

Unit: mm

A	B	C	D	E	L	G	H
7.0±0.3	6.6±0.3	2.2±0.2	1.8±0.3	3.0±0.3	7.7 Ref.	2.5 Ref.	3.5 Ref.

3. Schematic:

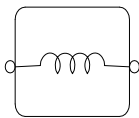

4. Material List:

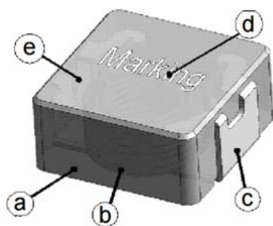

- (a) Core
- (b) Wire
- (c) Terminal
- (d) Ink
- (e) Paint

NOTE: Specifications subject to change without notice. Please check our website for latest information.



5. General Specification:

- (a) Reliability test for this part meets AEC-Q200 standard
- (b) Operating Temp. : -55°C to +125°C(including self-temperature rise)
- (c) Storage Temp. : -55°C to +125°C (on board)
- (d) Humidity Range. : 85 ± 3% RH
- (e) Heat Rated Current (Irms) will cause the coil temperature rise approximately Δt of 40°C
- (f) Saturation Current (Isat) will cause L0 to drop approximately 30%.
- (g) Part Temperature (Ambient+Temp. Rise) : Should not exceed 125°C under worst case operating conditions.
- (h) Storage condition (component in its packaging)
 - i) Temperature: Less than 40°C
 - ii) Humidity : 60% RH

NOTE: Specifications subject to change without notice. Please check our website for latest information.



6. Electrical Characteristics:

Part Number	Inductance L0 (uH) @ 0 A	Test Frequency, L	I rms (A) Typ.	I sat (A) Typ.	DCR(mΩ) Typ.@25°C	DCR(mΩ) Max.@25°C
PICQ0624HR10YF	0.10	100KHz/1.0V	30.0	70.0	1.4	1.7
PICQ0624HR15YF	0.15	100KHz/1.0V	30.0	45.0	1.8	2.3
PICQ0624HR20MF	0.20	100KHz/1.0V	23.0	40.0	1.9	2.8
PICQ0624HR22MF	0.22	100KHz/1.0V	21.0	34.0	2.0	3.2
PICQ0624HR33MF	0.33	100KHz/1.0V	18.0	30.0	3.6	4.4
PICQ0624HR36MF	0.36	100KHz/1.0V	17.0	29.0	3.8	4.6
PICQ0624HR47MF	0.47	100KHz/1.0V	15.0	26.0	4.8	5.1
PICQ0624HR56MF	0.56	100KHz/1.0V	13.0	24.0	5.5	6.5
PICQ0624HR60MF	0.60	100KHz/1.0V	13.0	22.0	5.7	6.9
PICQ0624HR68MF	0.68	100KHz/1.0V	13.0	21.0	6.4	7.2
PICQ0624HR82MF	0.82	100KHz/1.0V	11.0	17.0	8.0	9.5
PICQ0624H1R0MF	1.00	100KHz/1.0V	11.0	16.0	10.5	13.5
PICQ0624H1R5MF	1.50	100KHz/1.0V	9.0	15.0	17.0	20.0
PICQ0624H2R2MF	2.20	100KHz/1.0V	7.0	14.0	23.0	28.0
PICQ0624H3R3MF	3.30	100KHz/1.0V	6.0	10.0	34.0	39.0
PICQ0624H4R7MF	4.70	100KHz/1.0V	5.5	9.0	41.0	50.0
PICQ0624H5R6MF	5.60	100KHz/1.0V	5.0	8.0	56.0	62.0
PICQ0624H6R8MF	6.80	100KHz/1.0V	4.0	7.0	65.0	72.0
PICQ0624H8R2MF	8.20	100KHz/1.0V	3.6	6.0	81.0	95.0
PICQ0624H100MF	10.0	100KHz/1.0V	3.2	5.0	92.0	101
PICQ0624H150MF	15.0	100KHz/1.0V	2.5	3.5	150	180
PICQ0624H220MF	22.0	100KHz/1.0V	1.8	3.0	185	215

*Tolerance code : Y = $\pm 30\%$; M = $\pm 20\%$

Notes:

1) Isat Typ. and Irms Typ. value is derived based from accounting the upper limit tolerance into the inductance value.

NOTE: Specifications subject to change without notice. Please check our website for latest information.



7. Characteristics Curves:

PICQ0624HR10YF

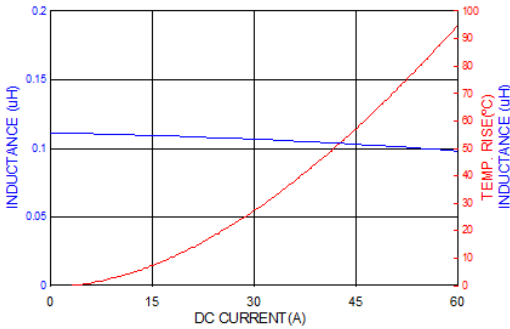

PICQ0624HR15YF

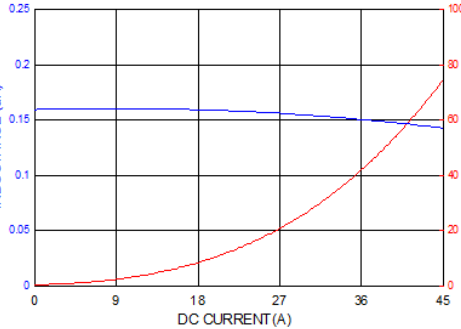

PICQ0624HR20MF

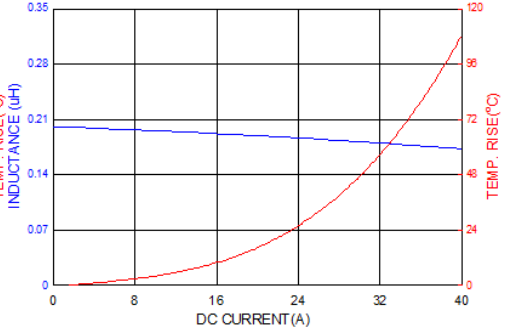

PICQ0624HR22MF

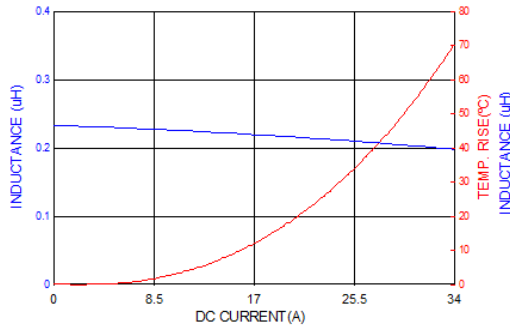

PICQ0624HR33MF

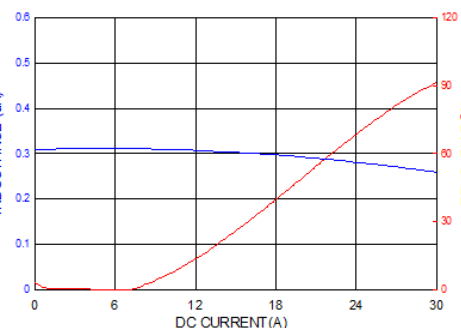

PICQ0624HR36MF

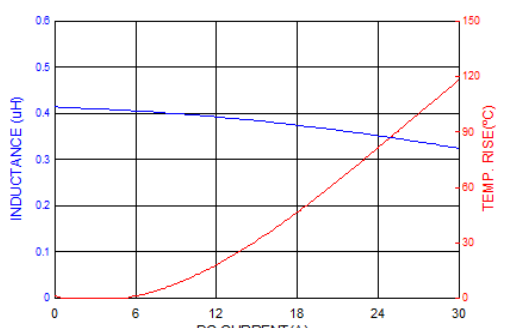

PICQ0624HR47MF

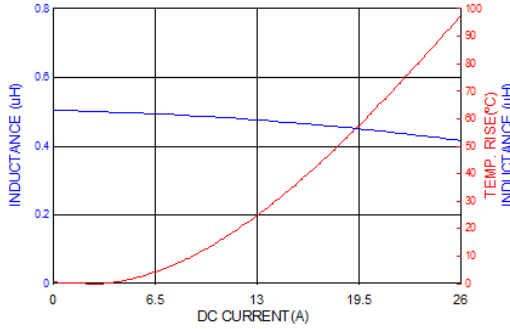

PICQ0624HR56MF

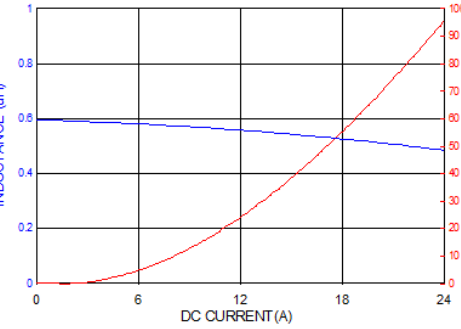

PICQ0624HR60MF

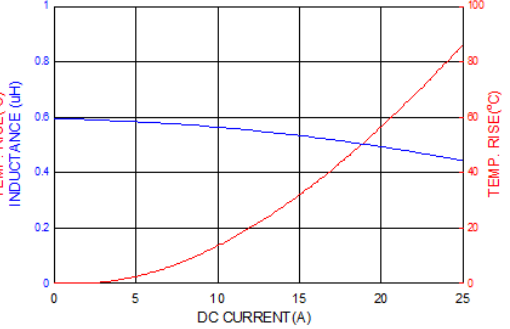

PICQ0624HR68MF

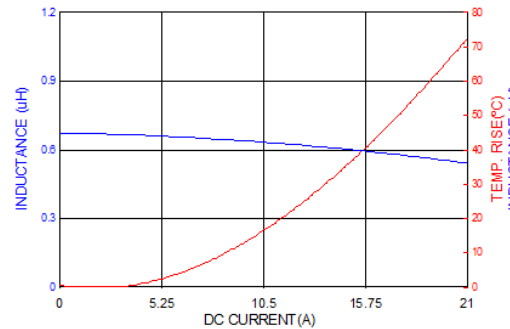

PICQ0624HR82MF

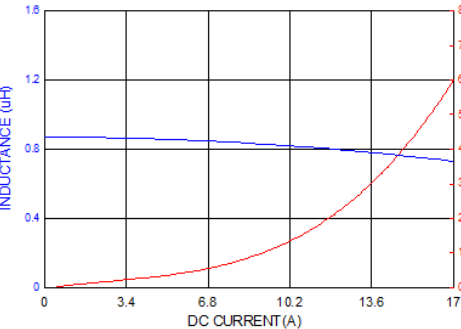

PICQ0624H1R0MF

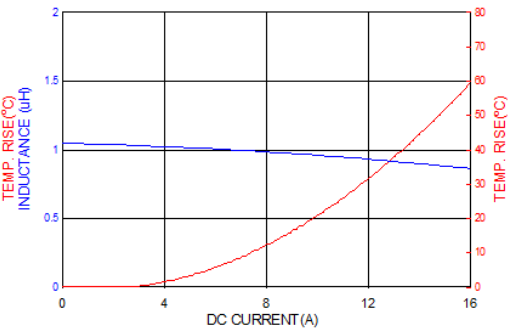

NOTE: Specifications subject to change without notice. Please check our website for latest information.



PICQ0624H1R5MF

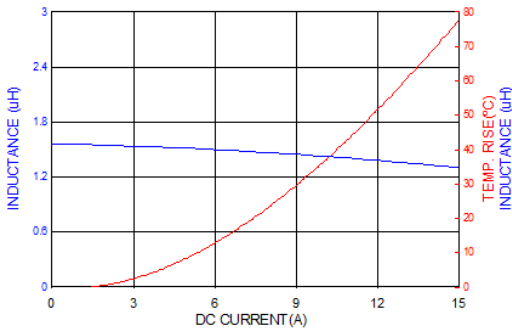

PICQ0624H2R2MF

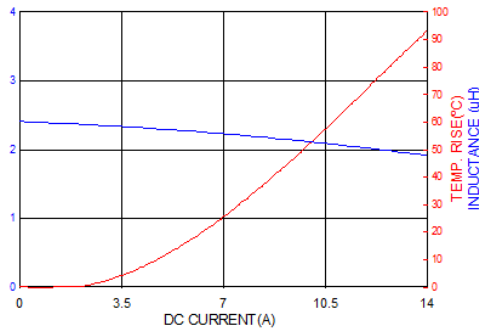

PICQ0624H3R3MF

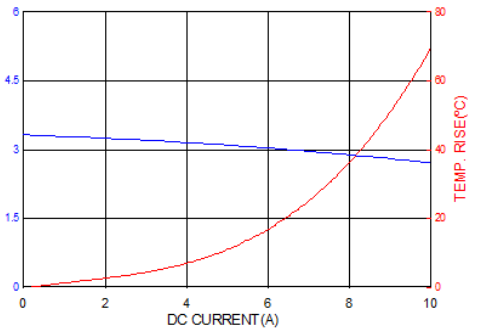

PICQ0624H4R7MF

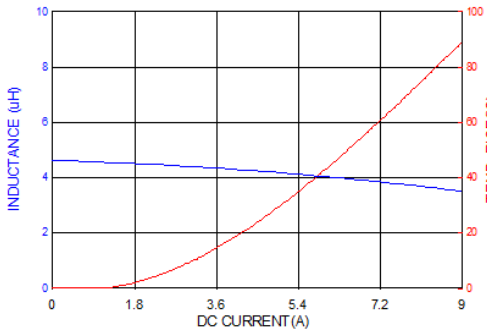

PICQ0624H5R6MF

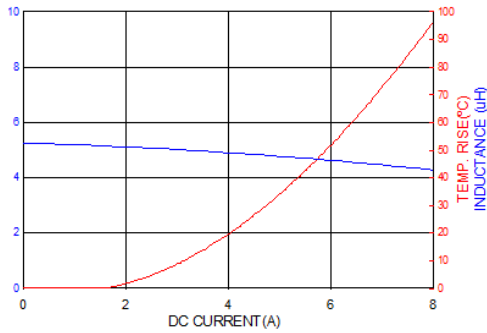

PICQ0624H6R8MF

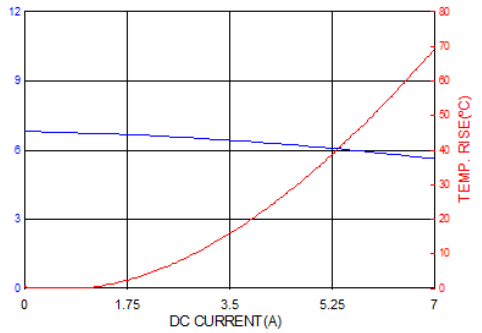

PICQ0624H8R2MF

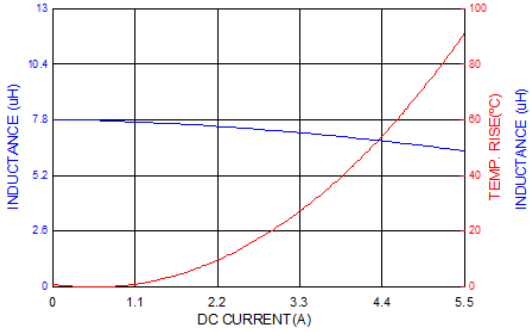

PICQ0624H100MF

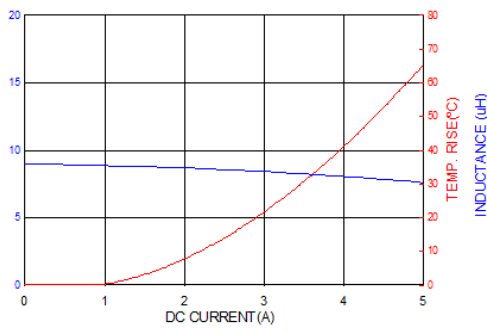

PICQ0624H150MF

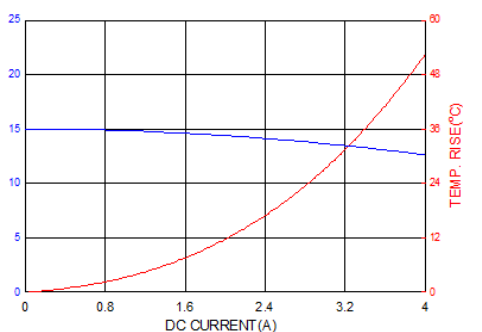

PICQ0624H220MF

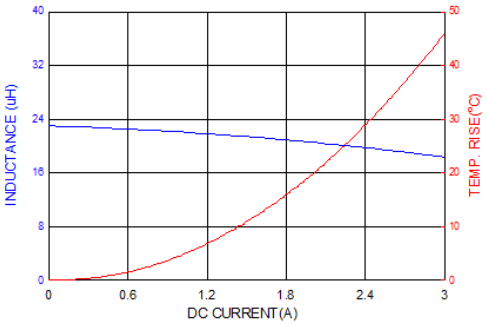

NOTE: Specifications subject to change without notice. Please check our website for latest information.



8. Soldering:

Mildly activated rosin fluxes are preferred. The minimum amount of solder can lead to damage from the stresses caused by the difference in coefficients of expansion between solder, chip and substrate. Our terminations are suitable for all re-flow soldering systems. If hand soldering cannot be avoided, the preferred technique is the utilization of hot air.

8-1 Solder Re-flow:

Recommended temperature profiles for re-flow soldering in Figure 1.

8-2 Soldering Iron (Figure 2):

Products attachment with soldering iron is discouraged due to the inherent process control limitations. In the event that a soldering iron must be employed the following precautions are recommended.

Note :

- a) Preheat circuit and products to 150°C.
- b) 355°C tip temperature (Max.)
- c) Never contact the ceramic with the iron tip
- d) 1.0mm tip diameter (Max.)
- e) Use a 20 watt soldering iron with tip diameter of 1.0mm
- f) Limit soldering time to 4~5 secs.

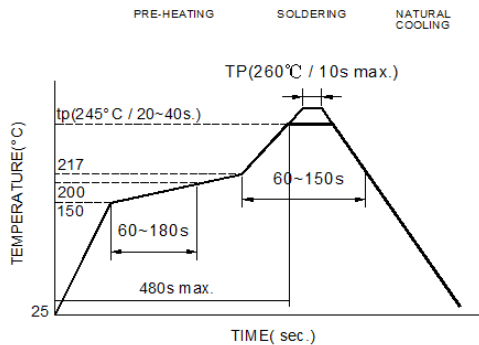

Reflow times: 3 times max.

Fig.1

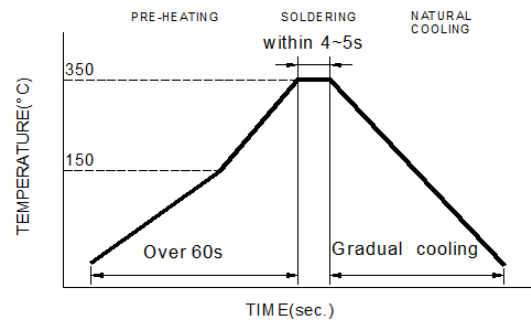

Iron Soldering times: 1 times max.

Fig.2

NOTE: Specifications subject to change without notice. Please check our website for latest information.



9. Packaging Information:

9-1 Reel Dimension

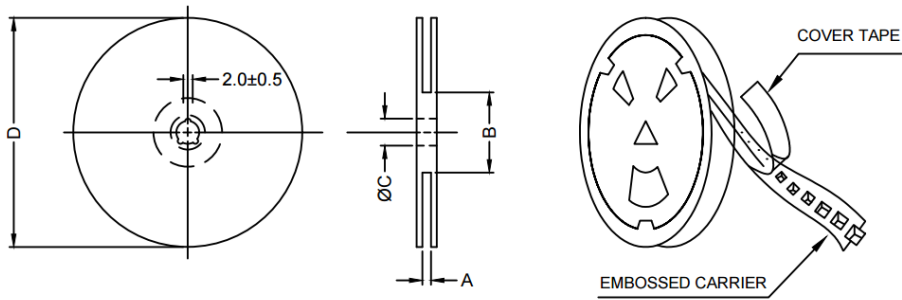

Type	A(mm)	B(mm)	C(mm)	D(mm)
13"x16mm	16.4+2/-0	100±2	13.0+0.5/-0.2	330

9-2 Tape Dimension

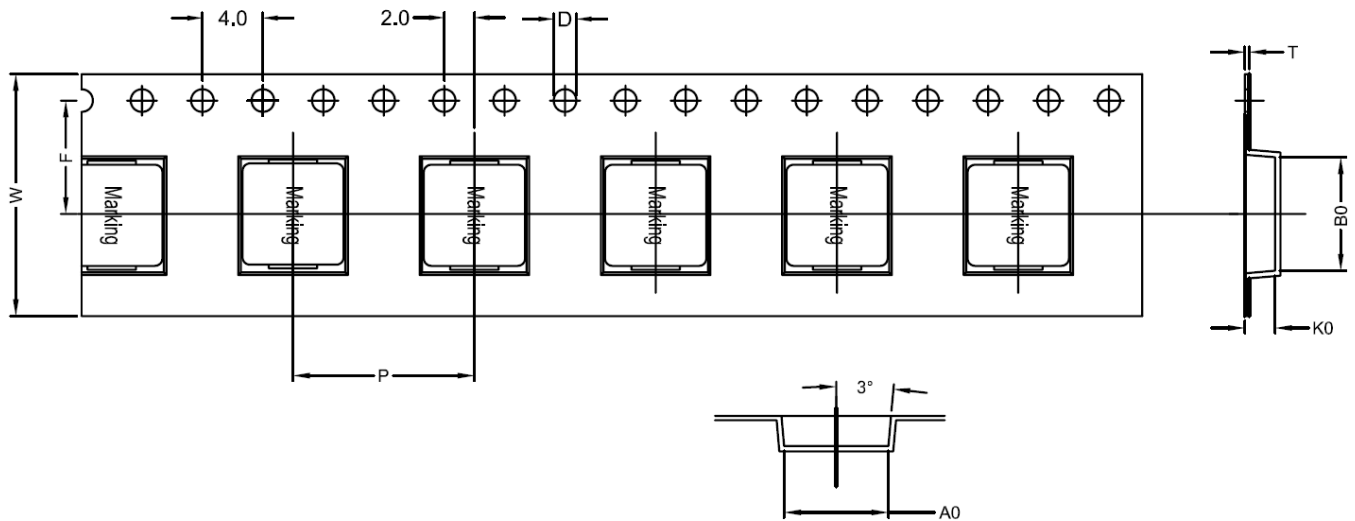

Series	Size	Bo(mm)	Ao(mm)	Ko(mm)	P(mm)	W(mm)	F(mm)	t(mm)	D(mm)
PICQ	0624	7.7±0.1	7.0±0.1	2.7±0.1	12.0±0.1	16.0±0.3	7.5±0.1	0.35±0.05	1.5±0.1

NOTE: Specifications subject to change without notice. Please check our website for latest information.

9-3 Packaging Quantity

PICQ	0624
Chip / Reel	1,500
Inner box	3,000
Carton	12,000

9-4 Tearing Off Force

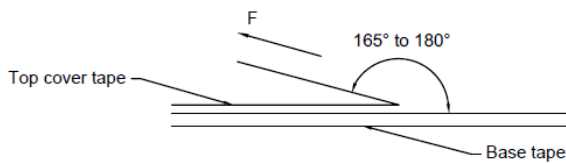

The force for tearing off cover tape is 10 to 130 grams in the arrow direction under the following conditions

Room Temp. (°C)	Room Humidity (%)	Room atm (hPa)	Tearing Speed mm/min
5~35	45~85	860~1060	300

Application Notice:

1. Storage Conditions:

To maintain the solderability of terminal electrodes:

- a) Recommended products should be used within 12 months from the time of delivery.
- b) The packaging material should be kept where no chlorine or sulfur exists in the air.

2. Transportation:

- a) Products should be handled with care to avoid damage or contamination from perspiration and skin oils.
- b) Vacuum pick up is strongly recommended for individual components.
- c) Bulk handling should ensure that abrasion and mechanical shock are minimized.

NOTE: Specifications subject to change without notice. Please check our website for latest information.

