

1. Part No. Expression:

**PIC0503HPR33MF**

(a) (b) (c) (d) (e)(f)

- a) Series Code
- b) Dimension Code
- c) Type Code
- d) Inductance Code
- e) Tolerance Code
- f) RoHS Compliant

2. Configuration & Dimensions:

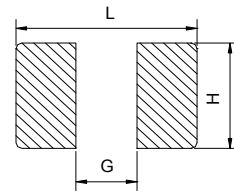
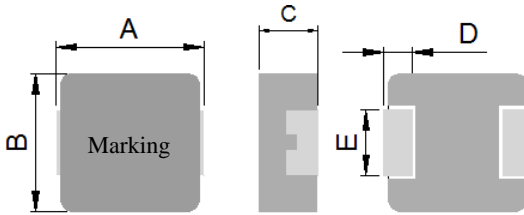

Recommended PC Board Pattern

Note:

1. The above PCB layout is for reference only.
2. Solder paste thickness of 0.12mm and above is recommended.
3. Marking : Top row – Inductance code, Bottom row – Year/World week.

Unit: mm

A	B	C	D	E	L	G	H
5.7±0.3	5.2±0.2	2.8±0.2	1.1±0.3	2.5±0.3	6.5 Ref.	2.5 Ref.	2.8 Ref.

3. Schematic:

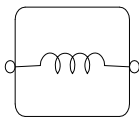

4. Material List:

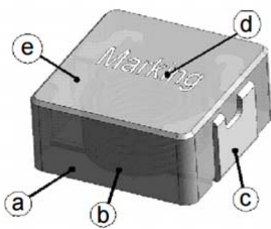

- (a) Core
- (b) Wire
- (c) Terminal
- (d) Ink
- (e) Paint

NOTE: Specifications subject to change without notice. Please check our website for latest information.



### 5. General Specification:

- (a) Operating Temp. : -40°C to +125°C (Including self - temperature rise).
- (b) Storage Temp. : -40°C to +125°C (on board).
- (c) Heat Rated Current (Irms) will cause the coil temperature rise approximately  $\Delta t$  of 40°C.
- (d) Saturation Current (Isat) will cause L0 to drop approximately 30%.
- (e) Part Temperature (Ambient+Temp. Rise). : Should not exceed 125°C under worst case operating conditions.
- (f) Humidity Range. : 85  $\pm$  2% RH.
- (g) Storage Condition (Component in its packaging).
  - i) Temperature: Less than 40°C.
  - ii) Humidity: 60% RH.

NOTE: Specifications subject to change without notice. Please check our website for latest information.



## 6. Electrical Characteristics:

Part Number	Inductance L0 (uH) @ 0 A	Test Frequency (Hz)	I rms (A) Typ.	I sat (A) Typ.	DCR (mΩ) Typ.	DCR (mΩ) Max.
PIC0503HPR10YF	0.10	1.0V/100K	23.0	27.0	2.5	3.0
PIC0503HPR22MF	0.22	1.0V/100K	15.5	21.0	3.7	4.4
PIC0503HPR33MF	0.33	1.0V/100K	13.7	19.0	4.5	5.2
PIC0503HPR47MF	0.47	1.0V/100K	12.2	16.0	6.7	7.1
PIC0503HPR68MF	0.68	1.0V/100K	10.2	13.5	8.2	9.0
PIC0503HPR82MF	0.82	1.0V/100K	9.3	13.0	10.2	11.9
PIC0503HP1R0MF	1.00	1.0V/100K	8.8	12.0	12.6	13.7
PIC0503HP1R5MF	1.50	1.0V/100K	7.2	11.0	18.7	20.7
PIC0503HP2R2MF	2.20	1.0V/100K	5.8	10.0	25.0	29.2
PIC0503HP3R3MF	3.30	1.0V/100K	5.0	8.5	41.0	49.2
PIC0503HP4R7MF	4.70	1.0V/100K	3.5	8.2	71.0	77.5
PIC0503HP5R6MF	5.60	1.0V/100K	3.0	7.0	88.5	102
PIC0503HP6R8MF	6.80	1.0V/100K	2.8	6.0	96.0	112
PIC0503HP8R2MF	8.20	1.0V/100K	2.6	4.5	99.0	114
PIC0503HP100MF	10.0	1.0V/100K	2.5	4.0	112	130
PIC0503HP150MF	15.0	1.0V/100K	1.9	2.5	210	242

Tolerance code : Y = ±30%; M = ±20%

Notes:

1) Isat Typ. and Irms Typ. value is derived based from accounting the upper limit tolerance into the inductance value.

NOTE: Specifications subject to change without notice. Please check our website for latest information.



7. Characteristics Curves:

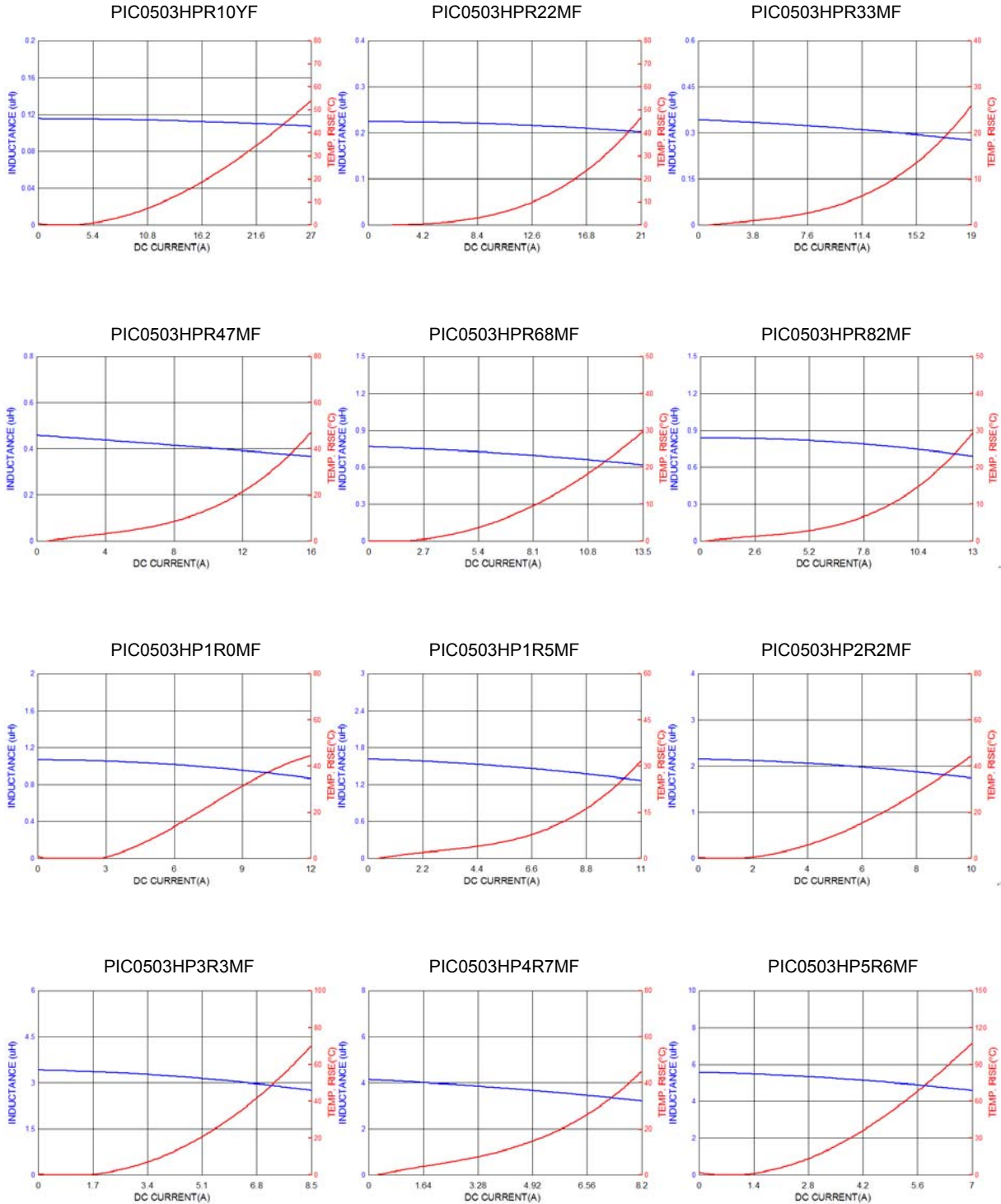

NOTE: Specifications subject to change without notice. Please check our website for latest information.



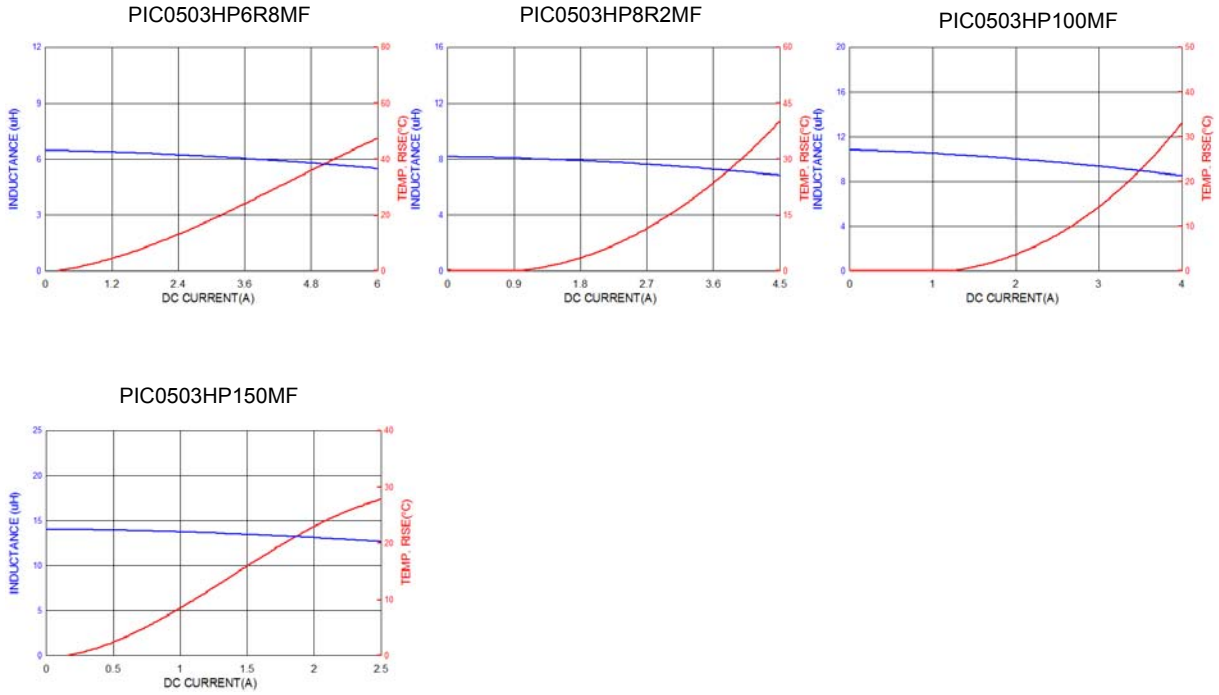

NOTE: Specifications subject to change without notice. Please check our website for latest information.



**8. Soldering:**

Mildly activated rosin fluxes are preferred. The minimum amount of solder can lead to damage from the stresses caused by the difference in coefficients of expansion between solder, chip and substrate. Our terminations are suitable for all re-flow soldering systems. If hand soldering cannot be avoided, the preferred technique is the utilization of hot air.

**8-1 Solder Re-flow:**

Recommended temperature profiles for re-flow soldering in Figure 1.

**8-2 Soldering Iron (Figure 2):**

Products attachment with soldering iron is discouraged due to the inherent process control limitations. In the event that a soldering iron must be employed the following precautions are recommended.

Note :

- a) Preheat circuit and products to 150°C.
- b) 355°C tip temperature (Max.)
- c) Never contact the ceramic with the iron tip
- d) 1.0mm tip diameter (Max.)
- e) Use a 20 watt soldering iron with tip diameter of 1.0mm
- f) Limit soldering time to 4~5 secs.

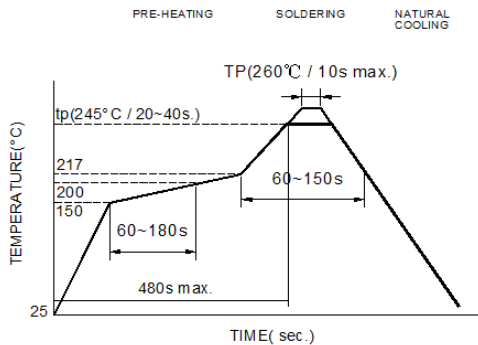

Reflow times: 3 times max.

Fig.1

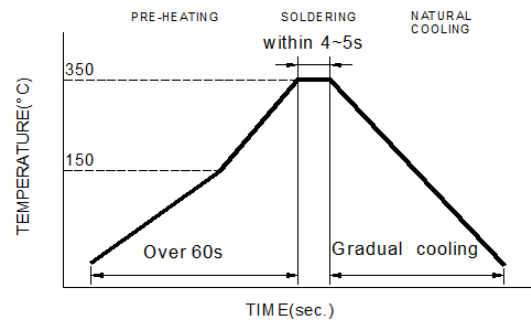

Iron Soldering times: 1 times max.

Fig.2

NOTE: Specifications subject to change without notice. Please check our website for latest information.



9. Packaging Information:

9-1 Reel Dimension

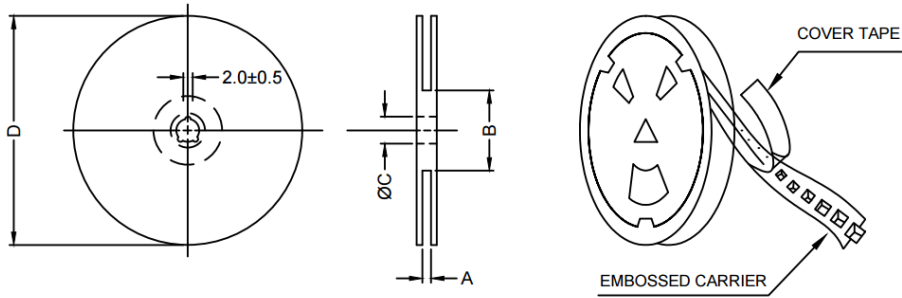

Type	A(mm)	B(mm)	C(mm)	D(mm)
13"x12mm	12.4+2/-0	100±2	13.0+0.5/-0.2	330

9-2 Tape Dimension

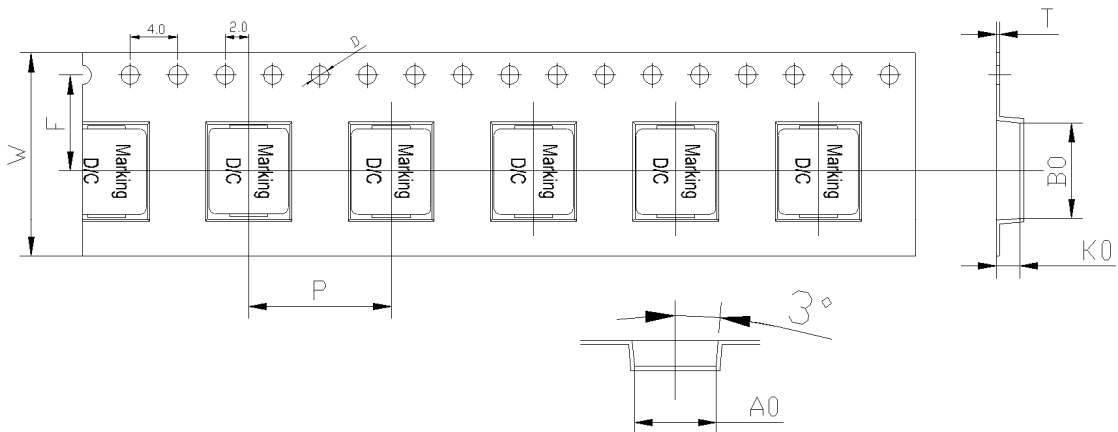

Series	Size	Bo(mm)	Ao(mm)	Ko(mm)	P(mm)	W(mm)	F(mm)	t(mm)	D(mm)
PIC	0503	6.2±0.1	5.5±0.1	3.3±0.1	8.0±0.1	12.0±0.3	5.5±0.1	0.35±0.05	1.5±0.1

9-3 Packaging Quantity

PIC	0503
Chip / Reel	2,000
Inner box	4,000
Carton	16,000

NOTE: Specifications subject to change without notice. Please check our website for latest information.

**9-4 Tearing Off Force**

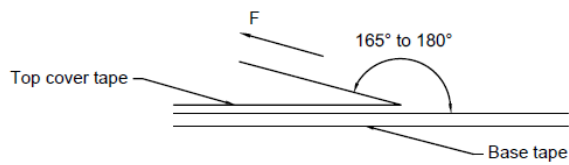

The force for tearing off cover tape is 10 to 130 grams in the arrow direction under the following conditions

Room Temp. (°C)	Room Humidity (%)	Room atm (hPa)	Tearing Speed mm/min
5~35	45~85	860~1060	300

**Application Notice:**

1. Storage Conditions:

To maintain the solderability of terminal electrodes:

- a) Recommended products should be used within 12 months from the time of delivery.
- b) The packaging material should be kept where no chlorine or sulfur exists in the air.

2. Transportation:

- a) Products should be handled with care to avoid damage or contamination from perspiration and skin oils.
- b) Vacuum pick up is strongly recommended for individual components.
- c) Bulk handling should ensure that abrasion and mechanical shock are minimized.

NOTE: Specifications subject to change without notice. Please check our website for latest information.

