

1. PART NO. EXPRESSION :

PDC0302 1R0 MZF
 (a) (b) (c) (d)(e)(f)

- (a) Series code
- (b) Dimension code
- (c) Inductance code : 1R0 = 1.0uH
- (d) Tolerance code : M = ±20%
- (e) X, Y, Z : Standard part
- (f) F : RoHS Compliant

2. CONFIGURATION & DIMENSIONS :

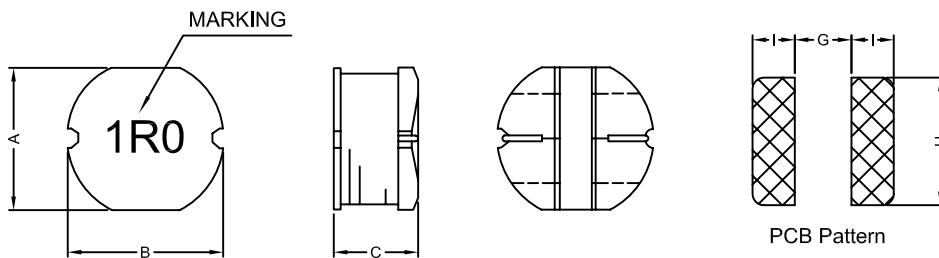

A	B	C	G	H	I
3.0±0.3	3.5±0.3	2.2±0.3	0.80 Ref.	3.50 Ref.	1.60 Ref.

3. SCHEMATIC :

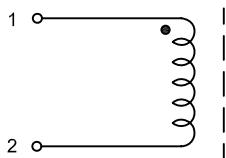

4. MATERIALS :

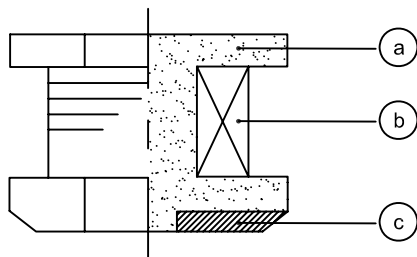

- (a) Drum Core
- (b) Wire
- (c) Electrode

5. GENERAL SPECIFICATION :

- a) TEMP. RISE : 40°C MAX.
- b) STORAGE CONDITION (COMPONENT IN ITS PACKAGING)
 - i) TEMPERATURE: -10°C TO 40°C
 - ii) HUMIDITY: 60%
- c) OPERATING TEMPERATURE : -40°C ~ +125°C



RoHS Compliant

NOTE : Specifications subject to change without notice. Please check our website for latest information.



6. ELECTRICAL CHARACTERISTICS :

Part No.	Inductance (μ H)	Test Frequency (Hz)	RDC (Ω) Max.	IDC (A) Drop10%
PDC03021R0MZF	1.0 \pm 20%	1V / 7.96M	0.055	2.50
PDC03021R4MZF	1.4 \pm 20%	1V / 7.96M	0.060	2.00
PDC03021R8MZF	1.8 \pm 20%	1V / 7.96M	0.070	1.90
PDC03022R2MZF	2.2 \pm 20%	1V / 7.96M	0.090	1.70
PDC03022R7MZF	2.7 \pm 20%	1V / 7.96M	0.100	1.60
PDC03023R3MZF	3.3 \pm 20%	1V / 7.96M	0.130	1.30
PDC03023R9MZF	3.9 \pm 20%	1V / 7.96M	0.150	1.20
PDC03024R7MZF	4.7 \pm 20%	1V / 7.96M	0.180	1.10
PDC03025R6MZF	5.6 \pm 20%	1V / 7.96M	0.210	1.00
PDC03026R8MZF	6.8 \pm 20%	1V / 7.96M	0.230	0.95
PDC03028R2MZF	8.2 \pm 20%	1V / 7.96M	0.310	0.90
PDC0302100MZF	10.0 \pm 20%	1V / 2.52M	0.350	0.80
PDC0302120MZF	12.0 \pm 20%	1V / 2.52M	0.390	0.70
PDC0302150MZF	15.0 \pm 20%	1V / 2.52M	0.540	0.65
PDC0302180MZF	18.0 \pm 20%	1V / 2.52M	0.620	0.60
PDC0302220MZF	22.0 \pm 20%	1V / 2.52M	0.720	0.55
PDC0302270MZF	27.0 \pm 20%	1V / 2.52M	0.820	0.50
PDC0302330MZF	33.0 \pm 20%	1V / 2.52M	1.100	0.45
PDC0302390MZF	39.0 \pm 20%	1V / 2.52M	1.200	0.40
PDC0302470MZF	47.0 \pm 20%	1V / 2.52M	1.600	0.38



RoHS Compliant

NOTE : Specifications subject to change without notice. Please check our website for latest information.

22.07.2019



SUPERWORLD ELECTRONICS (S) PTE LTD

PG. 2

7. PACKAGING INFORMATION :

(1) CONFIGURATION

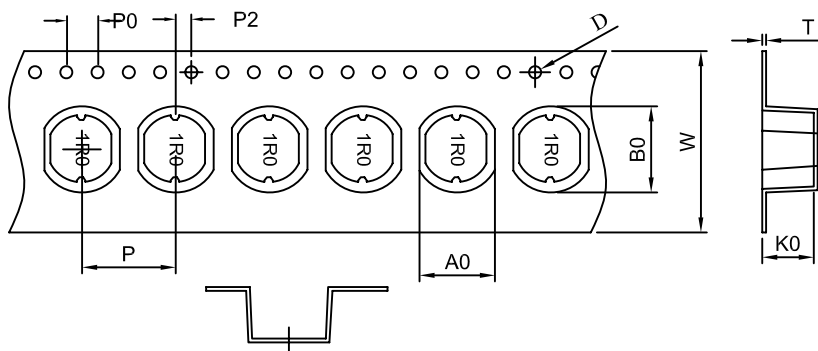
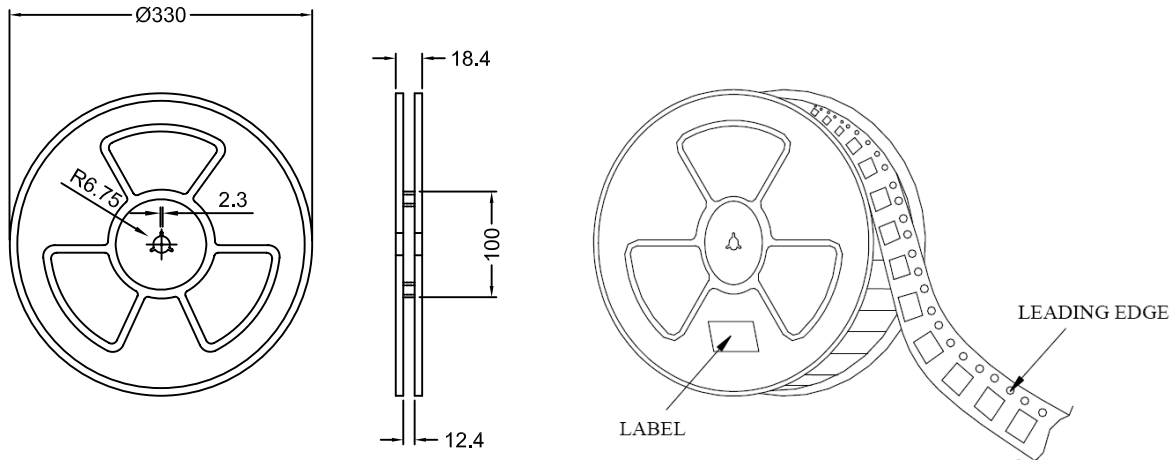

(2) DIMENSIONS

Unit:m/m

W	A0	B0	K0	P	D	P0	P2	T
12.0+0.3/-0.1	3.3±0.10	3.8±0.10	2.3±0.10	8.0±0.10	1.5 +0.1/-0	4.0±0.10	2.0±0.10	0.3



RoHS Compliant

NOTE : Specifications subject to change without notice. Please check our website for latest information.



SUPERWORLD ELECTRONICS (S) PTE LTD

22.07.2019

7. PACKAGING INFORMATION :

(3) TAPE DIMENSION

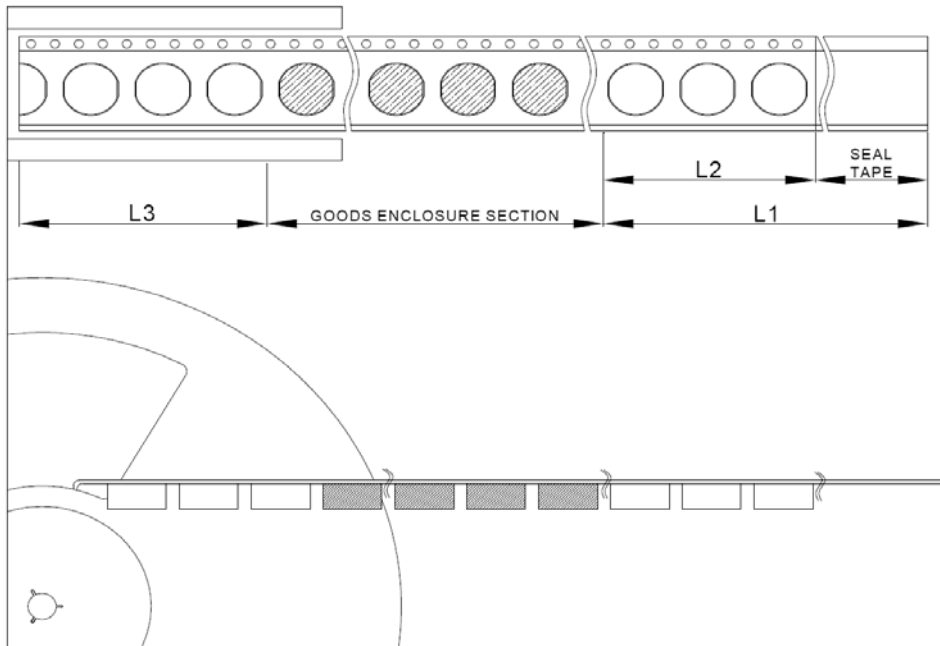

L1	LEADER SECTION LENGTH	MIN. 400mm
L2	START CARRIER TAPE LENGTH	MIN. 170mm
L3	TRAILER SECTION LENGTH	MIN. 170mm
	QUANTITY	3000PCS

(4) OUTER PACKING(UNIT:mm)

2 REEL PER INNER BOX (6000PCS)

5PCS INNER BOXES PER OUTER BOX (30KPCS)

OUTSIDE THE BOX (30KPCS)

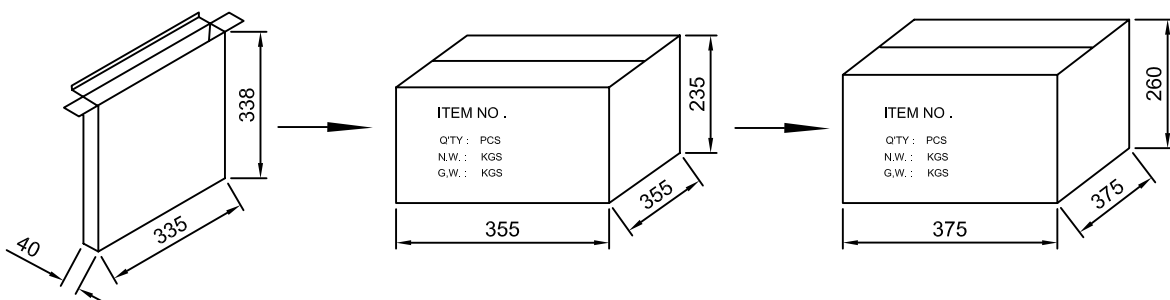

RoHS Compliant

NOTE : Specifications subject to change without notice. Please check our website for latest information.



7. PACKAGING INFORMATION :

(4) TAPING

- a. THE CARRIER TAPE AND SHIELD TAPE IS WOUND IN ONE CONTINUOUS REEL WITHOUT ANY JOINTED PORTIONS
- b. THE ANGLE BETWEEN THE SEAL TAPE DURING PEELOFF AND THE DIRECTION OF UNREELING SHALL BE 165° TO 180°. THE SEAL TAPE SHALL ADHERE UNIFORMLY TO THE CARRIER TAPE ALONG BOTH SIDES IN THE DIRECTION OF UNREELING. THE PEEL FORCE WITH A PEEL SPEED OF 300mm/MIN ± 10mm/MIN SHALL BE AS FOLLOWS :
 - 0.1N TO 1.0N FOR AN 8mm TAPE WIDTH.
 - 0.1N TO 1.3N FOR A 12mm~56mm TAPE WIDTH.

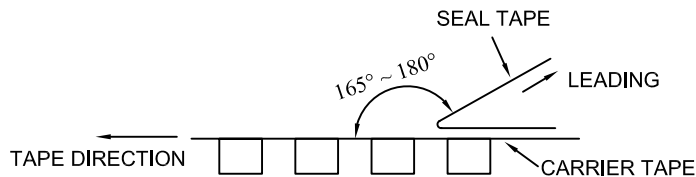

- c. PRECAUTION: COMPLETED REELS WITH RADIUS LESS THAN 40mm WILL RESULT IN THE FOLLOWING.
 - (I) CRACKS ON THE CARRIER TAPE
 - (II) SHIELD TAPE TEARING OFF

(5) PACKING

- a. POSITION OF COILS IN THE CARRIER TAPE: REFER TO THE SPECIFICATION OF THE INDIVIDUAL PART.
- b. THERE SHOULD NOT BE:
 - (I) WRONG POSITION OF GOODS IN THE CARRIER TAPE
 - (II) REJECTED GOODS IN THE CARRIER TAPE
 - (III) MISSING GOODS FROM THE CARRIER TAPE
- c. ONE REEL CONSISTS OF 3000 PIECES OF COIL.
- d. ON THE COMPLETED END OF THE REEL, THE CARRIER TAPE IS FIXED WITH A DRIVING TAPE.

(6) HANDLING PRECAUTION

- a. THE SURFACE OF THE PRODUCT CANNOT WITHSTAND A WEIGHT/FORCE EXCEEDING 9.8N.

(7) STORAGE

- a. GOODS TO BE STORED UNDER TEMPERATURES LESS THAN 60°C, WITH HUMIDITY NOT EXCEEDING 90%. IF THE STORAGE PERIOD IS LONG, REEL SHOULD BE REWOUND.



RoHS Compliant

NOTE : Specifications subject to change without notice. Please check our website for latest information.



SUPERWORLD ELECTRONICS (S) PTE LTD

22.07.2019

PG. 5