

CONTENTS

1. Part No. Expression
2. Configuration & Dimension
3. Material List
4. General Specifications
5. Electrical Characteristics
6. Characteristics Curves
7. Soldering and Mounting
8. Packaging Information

NOTE: Specifications subject to change without notice. Please check our website for latest information.



1. Part No. Expression

L 2 5 2 0 1 0 F W R 2 4 M

(a) (b) (c) (d) (e)

(a) Series Code

(b) Dimension Code

(c) Material Code

(d) Inductance Code

(e) Tolerance Code

2. Configuration & Dimensions: (Unit: mm)

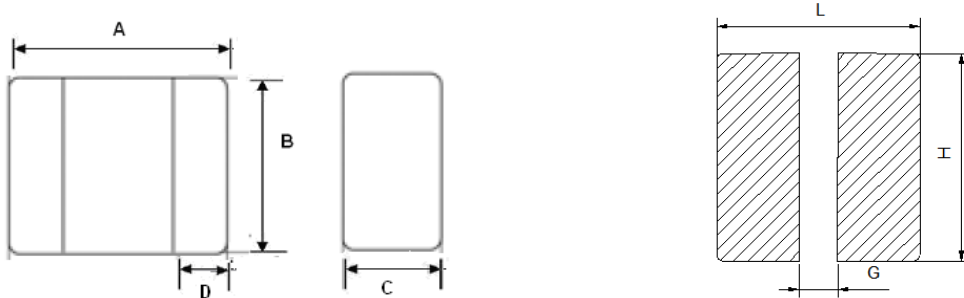

Recommended PCB Layout

A	B	C	D	L	G	H
2.5±0.2	2.0±0.2	1.0 max	0.5±0.3	2.8 Ref	1.2 Ref	2.3 Ref

NOTE: Specifications subject to change without notice. Please check our website for latest information.



3. Material List

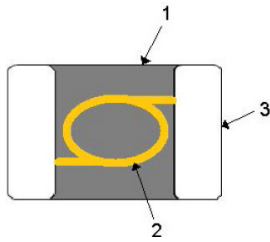

No.	Composition part	Material name
1	Alloy Body	Alloy Powder
2	Circuit-Copper	Copper Wire
3	Terminal	Silver paste

4. General Specifications

- (a) Operating Temp. : -40°C to +125°C (including self-temperature rise).
- (b) Storage Temp. : -40°C to +125°C (on board).
- (c) Irms : Heat Rated Current (Irms) will cause the coil temperature rise approximately ΔT of 40°C.
- (d) Isat : Saturation Current (Isat) will cause L0 to drop approximately 30%.
- (e) Storage Condition (Component in its packaging)
 - i) Temperature: Less than 40°C
 - ii) Humidity: 60% RH

NOTE: Specifications subject to change without notice. Please check our website for latest information.

5. Electrical Characteristics

Part Number	Inductance (uH)	Test Frequency (Hz)	I rms (A)	I sat (A)	DCR (mΩ)	
					typ.	max.
L252010FWR24M	0.24±20%	1M/1V	5.7	6.3	18	22
L252010FWR36M	0.36±20%	1M/1V	4.7	4.9	23	28
L252010FWR47M	0.47±20%	1M/1V	4.4	4.5	28	34
L252010FWR68M	0.68±20%	1M/1V	4.2	4.3	34	41
L252010FWR82M	0.82±20%	1M/1V	3.8	4.0	40	48
L252010FW1R0M	1.00±20%	1M/1V	3.4	3.7	52	62
L252010FW1R5M	1.50±20%	1M/1V	2.6	2.9	82	98
L252010FW2R2M	2.20±20%	1M/1V	2.2	2.3	105	126
L252010FW3R3M	3.30±20%	1M/1V	2.0	2.1	130	156

6. Characteristics Curves

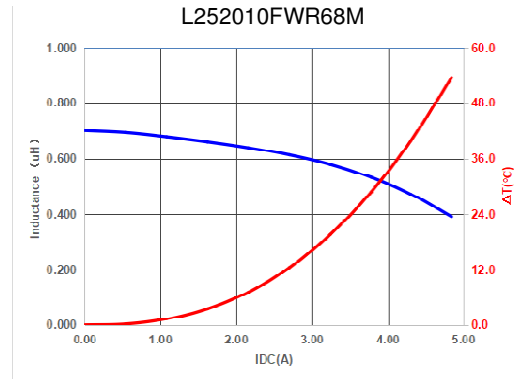
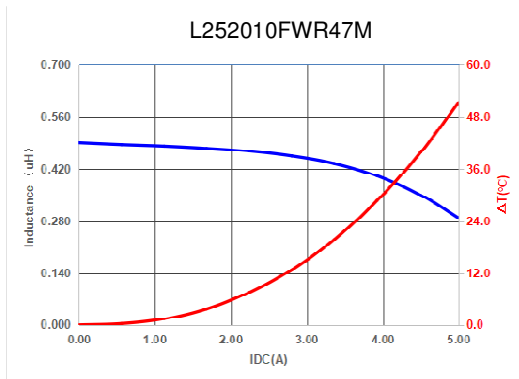
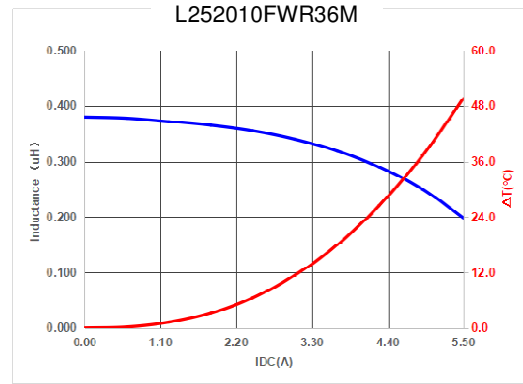
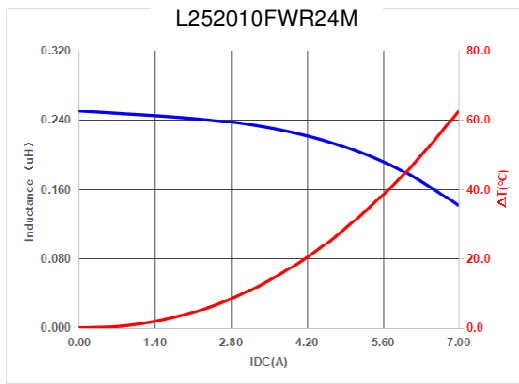

NOTE: Specifications subject to change without notice. Please check our website for latest information.



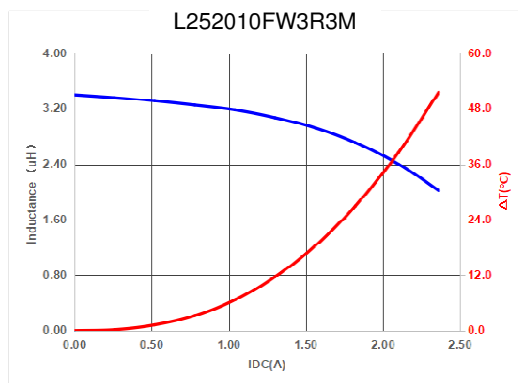
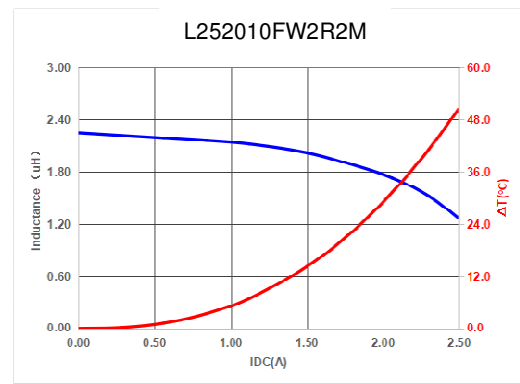
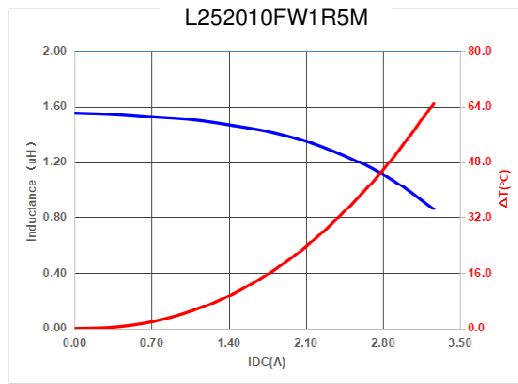
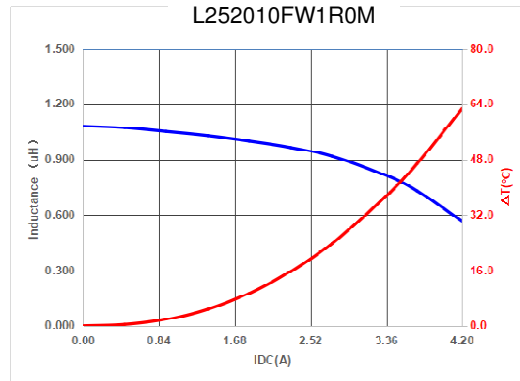
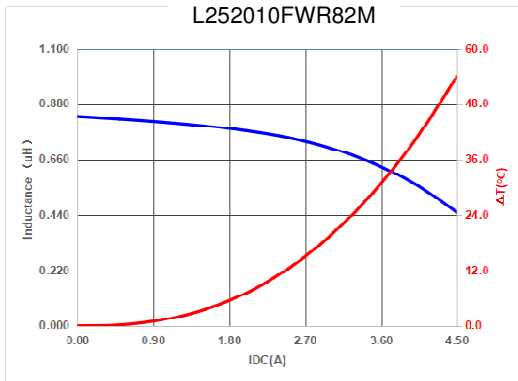

NOTE: Specifications subject to change without notice. Please check our website for latest information.



7. Soldering and Mounting

Mildly activated rosin fluxes are preferred. The terminations are suitable for re-flow soldering systems. If hand soldering cannot be avoided, the preferred technique is the utilization of hot air soldering tools.

7-1 Soldering Re-flow

Recommended temperature profiles for lead free re-flow soldering in Figure 1. Table 1.1&1.2 (J-STD-020E)

7-2 Soldering Iron

Products attachment with soldering iron is discouraged due to the inherent process control limitations. In the event that a soldering iron must be employed the following precautions are recommended (Fig 2).

Note:

- a) Preheat circuit and products to 150°C.
- b) 355°C tip temperature (Max).
- c) Never contact the ceramic with the iron tip.
- d) 1.0mm tip diameter (Max).
- e) Use a 20 Watt soldering iron with tip diameter of 1.0mm.
- f) Limit soldering time to 4~5 secs.

Fig.1 IR Soldering Reflow

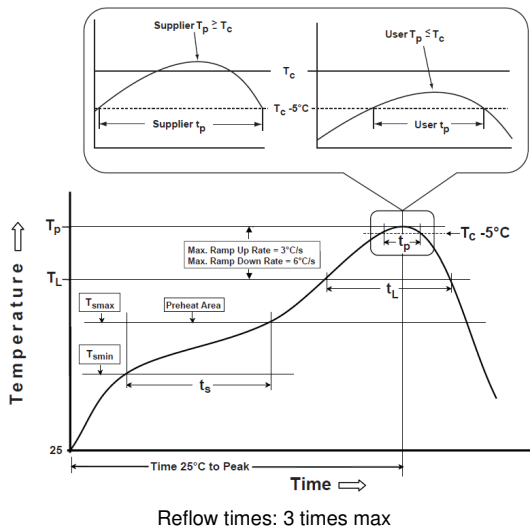
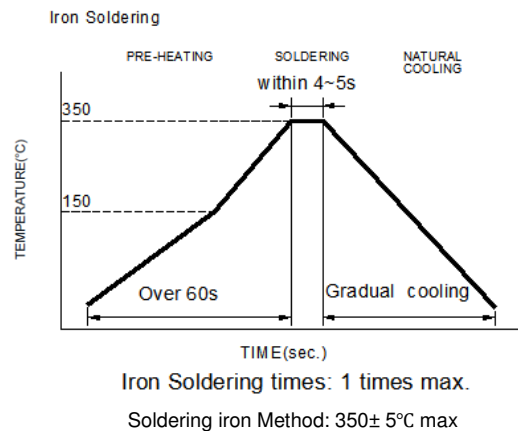

Fig.2 Iron soldering temperature profiles



NOTE: Specifications subject to change without notice. Please check our website for latest information.



Table (1.1): Reflow Profiles

Profile Type:	Pb-Free Assembly
Preheat -Temperature Min(T_{smin}) -Temperature Max(T_{smax}) -Time(t_s)from(T_{smin} to T_{smax})	150°C 200°C 60-120seconds
Ramp-up rate(T_L to T_p)	3°C/second max.
Liquidus temperature(T_L) Time(t_L)maintained above T_L	217°C 60-150 seconds
Classification temperature(T_c)	See Table (1.2)
Time(t_p) at T_c - 5°C (T_p should be equal to or less than T_c .)	* < 30 seconds
Ramp-down rate(T_p to T_L)	6°C /second max.
Time 25°C to peak temperature	8 minutes max.

T_p : maximum peak package body temperature, T_c : the classification temperature.

For user (customer) T_p should be equal to or less than T_c .

* Tolerance for peak profile temperature (T_p) is defined as a supplier minimum and a user maximum.

Table (1.2) Package Thickness/Volume and Classification Temperature (T_c)

	Package Thickness	Volume mm ³ <350	Volume mm ³ 350-2000	Volume mm ³ >2000
PB-Free Assembly	<1.6mm	260°C	260°C	260°C
	1.6-2.5mm	260°C	250°C	245°C
	≥2.5mm	250°C	245°C	245°C

Reflow is referred to standard IPC/JEDEC J-STD-020E °

8. Packaging Information

8-1 Reel Dimension

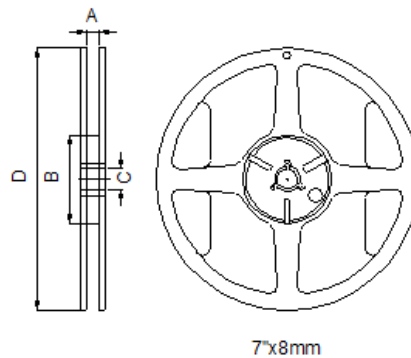

Type	A(mm)	B(mm)	C(mm)	D(mm)
7"x8mm	9.0±0.5	60±2	13.5±0.5	178±2

NOTE: Specifications subject to change without notice. Please check our website for latest information.

8-2 Tape Dimension

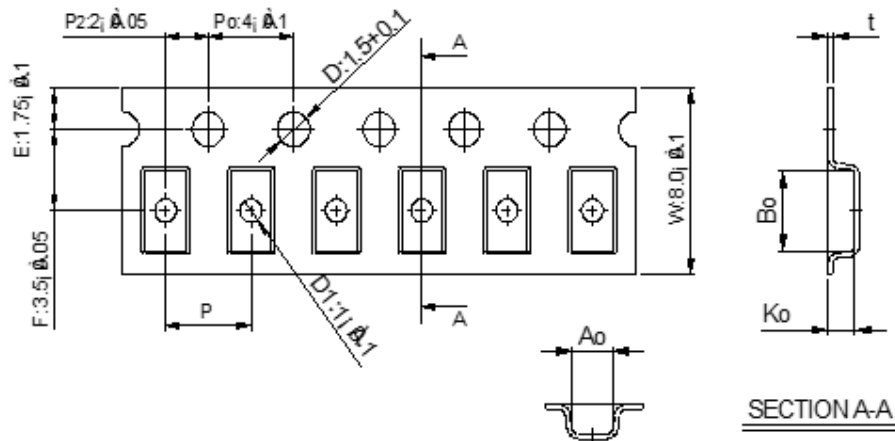

Size	Bo(mm)	Ao(mm)	Ko(mm)	P(mm)	t(mm)
252010	2.90±0.1	2.30±0.1	1.15±0.1	4.0±0.1	0.23±0.05

8-3 Packaging Quantity

Chip Size	252010
Chip/Reel	3000

8-4 Tearing Off Force

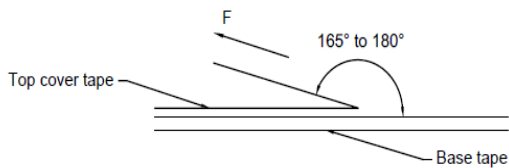

The force for tearing off cover tape is 10 to 100 grams in the arrow direction under the following conditions.

Tearing Speed mm	Room Temp. (°C)	Room Humidity (%)	Room atm (hPa)
300±10%	5~35	45~85	860~1060

NOTE: Specifications subject to change without notice. Please check our website for latest information.

Application Notice:

1. Storage Conditions:

To maintain the solderability of terminal electrodes:

- a) Recommended products should be used within 12 months from the time of delivery.
- b) The packaging material should be kept where no chlorine or sulfur exists in the air.

2. Transportation:

- a) Products should be handled with care to avoid damage or contamination from perspiration and skin oils.
- b) The use of tweezers or vacuum pick up is strongly recommended for individual components.
- c) Bulk handling should ensure that abrasion and mechanical shock are minimized.

NOTE: Specifications subject to change without notice. Please check our website for latest information.

